

BALTIC HUB T5 OFFSHORE WIND TERMINAL PROJECT

Technical Volume 2

Part 2.1 Employer's Requirements
Section 2- Design Criteria

Client: Istrana

Reference: PC1063-RHD-T5-ZZ-RP-PM-0002

Status: S4/P09

Date: 16 April 2024

HASKONINGDHV POLSKA SP. Z O.O.

Dzielna 60
01-029 Warszawa
Water & Maritime

+48 22 53 13 400 **T**
+48 22 635 00 20 **F**
info@pl.rhdhv.com **E**
royalhaskoningdhv.com **W**

Document title: Technical Volume 2

Document short title: Design Criteria
Reference: PC1063-RHD-T5-ZZ-RP-PM-0002
Status: P09/S4
Date: 16 April 2024
Project name: Baltic Hub T5 Offshore Wind Supply Base Project
Project number: PC1063
Author(s): R. Marshall

Drafted by: R. Marshall, O.Alaoui

Checked by: A.To, O. Alaoui

Date: 16 April 2024

Approved by: A.To

Date: 16 April 2024

Classification

Project related

Unless otherwise agreed with the Client, no part of this document may be reproduced or made public or used for any purpose other than that for which the document was produced. HaskoningDHV Polska Sp. z o.o. accepts no responsibility or liability whatsoever for this document other than towards the Client.

Please note: this document contains personal data of employees of HaskoningDHV Polska Sp. z o.o.. Before publication or any other way of disclosing, this report needs to be anonymized, unless anonymisation of this document is prohibited by legislation.

Contents

2	Introduction	8
2.1	Background	8
2.2	Scope of Document	8
2.3	Design Life	8
2.4	Design Codes, Standards and Guidelines	9
2.5	Units, Levels, Datum and Co-ordinate Systems	14
2.6	Site Data	14
2.6.1	Water Levels	15
2.6.2	Sea Level Rise	16
2.6.3	Tidal Lag	16
2.6.4	Waves	16
2.6.5	Wind	16
2.6.6	Sea Ice	18
2.6.7	Temperature	18
2.6.8	Bathymetric Surveys	18
2.6.9	Seismic Design	19
2.7	Quay and Retaining Wall Structures	19
2.7.1	OWSB Outbound Berth / Future Container Berth	19
2.7.2	Seabed Reinforcement for WIV Jack Up Operations	26
2.7.3	OWSB Inbound Berth	26
2.7.4	OWSB RoRo Berth	33
2.7.5	Easterly Interface Wall	37
2.7.6	Gantry Cranes and Crane Rails	38
2.8	Vessel Scour Protection	40
2.9	Surfacing / Paving	41
2.9.1	Definition of Imposed Loads	41
2.9.2	Design Loads	42
2.9.3	Further Requirements - Ro-Ro Area	49
2.9.4	Further Requirements – Access Road	49
2.9.5	Further Requirements – Crew Transfer Route	49
2.9.6	Ground Settlement	49
2.10	Surface Water Drainage	51
2.10.1	OWSB – Surface Water Drainage	51
2.10.2	Design Rainfall Criteria	51
2.11	Foul Drainage	53
2.11.1	OWSB – Foul Water Drainage	53
2.11.2	Design Methodology	53
2.11.3	Minimum Cover to Pipes	53
2.11.4	Materials and Structural Form	53
2.11.5	Manhole Diameters	54

2.12	Potable Water System	54
2.12.1	OWSB – Potable Water	54
2.12.2	Scope	55
2.12.3	Existing T1 & T2 Potable Water System	55
2.12.4	Potable Water Demand for Future Container Terminals	56
2.12.5	Above Ground Storage Tanks	57
2.12.6	Circulation Pumps	58
2.12.7	Distribution Network	58
2.12.8	Incoming Potable Water Mains Supply	58
2.12.9	Valve Chambers	58
2.12.10	Bunkering Points	58
2.12.11	Washout Chambers	58
2.13	Fire Water System	59
2.13.1	OWSB – Fire Fighting Requirements	59
2.13.2	Fire Water Pump Facility	60
2.13.3	Existing Above Ground Storage Tanks	60
2.13.4	Below Ground Hydrants	60
2.13.5	Valve Chambers	60
2.13.6	Distribution Network	60
2.14	Electrical	61
2.14.1	OWSB – Electrical Requirements	61
2.14.2	Power Supply	61
2.14.3	OWSB Lighting	62
2.14.4	Electrical Distribution System	62
2.15	Fuel Bunkering System	63
2.15.1	Design Life	63
2.15.2	Products to be Handled	63
2.15.3	Fuel Bunkering Demand	63
2.15.4	Design Pressure	64
2.15.5	Design Vessels	64
2.16	OWSB – Buildings	64
2.16.1	Site security and fencing requirements.	64
2.16.2	CCTV Surveillance	65

List of Tables

Table 2-1– Design Working Life of Civils and Marine Works Elements	8
Table 2-2: Characteristic states - Gdansk Port Polnocny (Poland) water gauge from 2006-2020	15
Table 2-3 – Probabilities of occurrence and return periods of the positive water levels in Gdansk (Source: Wiśniewski & Wolski,2009)	15
Table 2-4 – Probabilities of occurrence and return periods of the negative water levels in Gdansk (Wroblewski, 1992)	15
Table 2-5 – Wave conditions	16
Table 2-6 – Frequency of winds in % for all directions 2012-2022	17
Table 2-7 – Gdansk temperature extremes	18
Table 2-8 Design OWSB WIV vessel parameters	19
Table 2-9 – Design container vessel parameters	20
Table 2-10 – Berthing parameters for container vessels	20
Table 2-11 – Berthing parameters for OWSB vessels	21
Table 2-12 – Quay geometry	22
Table 2-13 – Mooring equipment	23
Table 2-14 – Quay equipment and layout	23
Table 2-15 Dimensions of terminal tractors / IMVs	25
Table 2-16 Terminal tractor/IMV axle loads	25
Table 2-17 – OWSB inbound berth design vessels	26
Table 2-18 – Berthing parameters for OWSB inbound vessels	26
Table 2-19 – Quay geometry	27
Table 2-20 – Mooring equipment	27
Table 2-21 – Quay equipment and layout	28
Table 2-22 Design OWSB vessel parameters	33
Table 2-23 – Berthing parameters for OWSB vessels	34
Table 2-24 – Quay geometry	35
Table 2-25 – Mooring equipment	36
Table 2-26 – Quay equipment and layout	36
Table 2-27 – Quay geometry	37
Table 2-28 – Quay equipment and layout	37
Table 2-29 – Quayside gantry crane rails	38
Table 2-30 – Quayside gantry crane general parameters and loads	38
Table 2-31 – Quayside gantry crane cable connection pits and other fixtures	39
Table 2-32 Load Summary	48
Table 2-33 - OWSB Potable Water Demand	54

Table 2-34 – DCT Water Consumption Figures	56
Table 2-35 – Future Container Terminal Potable Water Demands	57
Table 2-36: LV Electrical requirements for the OWSB	61
Table 2-37: MV Electrical requirements for the OWSB	Error! Bookmark not defined.
Table 2-38: OWSB Lighting Levels	62
Table 2-39: Electrical Distribution Parameters	63

Table of Figures

Figure 2-1 Wheel arrangement for terminal tractors / IMVs	25
Figure 2-2: Mooring and Breast Dolphin arrangement.	35
Figure 2-3 Uniformly distributed load calculation	41
Figure 2-4 Maximum ground pressure calculation	41
Figure 2-5 Baseline ground pressure calculation	42
Figure 2-6 Self-propelled modular transportation vehicle (SPMT)	42
Figure 2-7 Liebherr LR 1750/2 crane arrangement	43
Figure 2-8 Liebherr LR 1750/2 crane load	43
Figure 2-9 Liebherr LR 11350 P1800 crane	44
Figure 2-10 Liebherr LR 11350 P1800 pressure calculation	44
Figure 2-11 Nacelle	45
Figure 2-12 Nacelle pressure calculation	45
Figure 2-13 Tower frames	46
Figure 2-14 Tower frames pressure calculation	46
Figure 2-15 - Maximum rain intensity at predetermined time curve (2016 07 14 max. sum) and rain intensity curve from the beginning of the 14 July 2016 (2016 07 14) event together with IDF curves of rain models	52
Figure 2-16 - Maximum rain sum at predetermined time curve (2016 07 14 max. sum) and rain sum curve from the beginning of the 14 of July 2016 (2016 07 14) together with DDF curves of rain models	52

2 Introduction

2.1 Background

This section comprises the technical requirements and design parameters for the Works and shall be read in conjunction with the other parts of these Employer's Requirements.

2.2 Scope of Document

This Design Criteria has been prepared with the following objectives:

- To summarise the key project requirements, and explain how these shall be accommodated in the design;
- To set out any design clarifications, including key risks and envisaged mitigation measures; and
- To describe the design codes, standards, methods and values that shall be adopted in the design.

2.3 Design Life

The design working life is defined as the period for which structural elements, surfacing, pavements, buildings, Electrical and Mechanical ("E&M") systems, services, drainage systems etc. are to be used for their intended purposes with acceptable routine maintenance, but without major repair and/or replacement being necessary.

The levels of maintenance within this design life period will be in accordance with Table 2-1 below or, if not specified in the table, shall comply with the relevant design codes and standards.

Table 2-1– Design Working Life of Civils and Marine Works Elements

Element	Design Working Life	Period to First (non-routine) Maintenance	Routine Maintenance by Employer	Unacceptable Repair/ Replacement
Concrete	75 years (Marine)	75 years	None	Cutting out/replacement of defective/spalled concrete and corroded reinforcement
	75 years (Land)	75 years	None	
Steelwork	75 years (Marine)	15 years	Re-coating of protective treatment systems not earlier than after 15 years (doesn't apply to lighting masts)	Cutting out/replacement of defective/corroded steel or its fixings; welding of steel plates onto existing steel structures/elements
	75 years (Land)	15 years		
Temporary T4 Interface Wall	75 years	15 years	None	Cutting out/replacement of defective/corroded steel or its fixings; welding of steel plates onto existing steel structures/elements

Pavements, Roadways & Drainage Channels	30 years	30 years	None	Any removal/ replacement to correct out of tolerance settlement in areas where slope or settlement criteria have been exceeded. Replacement of defective/cracked concrete, expansion joints, drainage channels
Temporary Compacted Crushed Rock Surfacing (inc impermeable taking membrane)	15 years	NA	As and when required for local surface repairs, regrading and upkeep so desired levels. Topping up and recompacting	Any removal/ replacement of surfacing rock which results in major excavation that would require disruptive or ceasing operations in the yard
Fencing & Gates	30 years	15 years	Repainting of gates and fence posts	Any removal/replacement of any base, post, gates, fencing.
Temporary Fencing & Gates	15 years	5 years	Repainting of gates and fence posts	Any removal/replacement of any base, post, gates, fencing.
Bollards	30 years	15 years	Re-coating of protective treatment systems not earlier than after 15 years	Repair/replacement of any component part
Fenders and Fender Panels	30 years	15 years	Re-coating of protective treatment systems every 15 years	Repair/replacement of any component part
Scour Protection and Rock Revetment	75 years	75 years	Refer to Section 7	
Cathodic Protection (galvanic anode system) – if applicable	75 years	15 years	Replacement of sacrificial anodes	Repair/replacement of any fixings for sacrificial anodes
Electrical powering net, trafostations, switchgears etc.	30 years	To suit individual maintenance programmes	Periodic normal and routine maintenance according to manufacturers' manuals	Any removal/replacement of any items or parts of plant, controls, cables, ducts, components,
Fire services	30 years	To suit individual maintenance programmes	Periodic normal and routine maintenance according to manufacturers' manuals	Any removal/replacement of any items or parts, controls, pipes, valves; re-coating of water tanks
Installations and service utilities	20 years	To suit individual maintenance programmes	Periodic normal and routine maintenance of all items of plant/controls in accordance with manufacturers' manual	Any removal/replacement of any items or parts of plant, controls pipes, cables, ducts, components, accessories, fittings, fixings etc. but excluding consumables
Permanent Terminal Buildings and Structures	50 years	To suit individual maintenance programmes	Periodic normal and routine maintenance of all structural items	Complete rebuild, or major repairs which prevent the function of the building to continue which will adversely affect the operations of the terminal

2.4 Design Codes, Standards and Guidelines

The design, manufacture, provision, installation and construction of all temporary and permanent works shall as a minimum comply with the latest editions of Polish, European (ISO) Specifications, Codes of Practice, and all statutory regulations.

European and British Standards, or other recognised international guidelines shall be used if the subject is not adequately covered by the Polish standards.

A consistent, coherent and compatible set of standards shall be used, appropriate to the form of construction and the environment. Mixing parameters from different codes and standards is not permitted and wherever possible, the complete design of any element shall be completed in accordance with one code.

The following list of codes of practice and standards to be considered by the Contractor is not exhaustive, alternatives may be proposed and, where required, other codes and standards not on the list may be used subject to compliance with the general requirements above, and to the approval of the Engineer.

Standard No.	
Foundations, Geotechnics and Earthworks	
EN 1997-1	Eurocode 7: Geotechnical design: General rules
EN 1997-2	Eurocode 7: Geotechnical design: Ground investigation and testing
EN 1993-5	Eurocode 3: Design of steel structures: Piling
-	Pile Design and Construction Practice, Sixth Edition by MJ Tomlinson and J Woodward
EAU 2012	Recommendations of the Committee for Waterfront Structures Harbour and Waterways (9th Edition)
CIRIA C760, 2017	Guidance on embedded retaining wall design
Structural	
EN 1990	Eurocode 0: Basis of structural design
EN 1991-1	Eurocode 1: Actions on structures
EN 1992-1	Eurocode 2: Design of concrete structures
EN 1993-1	Eurocode 3: Design of steel structures
EN 1994-1	Eurocode 4: Design of composite steel and concrete structures
CIRIA C766	Control of cracking caused by restrained deformation in concrete
BPA Heavy Duty Pavements Manual	Interpave, The structural design of heavy-duty pavements for ports and other industries, Edition 4, December 2008
PIANC Report No.165	Design and Maintenance of Container Terminal Pavements (2015)
NCPP	Guide for Roller-Compacted Concrete Pavements, National Concrete Pavement Technology Center, August 2010
-	Structural Design of Roller-Compacted Concrete for Industrial Pavements, Portland Cement Association (1988)
-	Britpave guide to Roller Compacted Concrete Pavements, 1st Edition 2013
ACI318, 2011	Building Code Requirements for Structural Concrete (for guidance where Eurocode does not cover),
BPA Heavy Duty Pavements Manual	Interpave, The structural design of heavy-duty pavements for ports and other industries, Edition 4, December 2008
Concrete Society Technical Report 34	Concrete Industrial Ground Floors, 4th Edition
DBV-Merkblatt	Steel Fibre Reinforced Industrial Concrete Floors
CUR-Aanbeveling 36	Design of concrete floors and pavements on elastic foundations
KTKNS 2014	Catalog of typical constructions rigid surfaces (GDDKiA)

KTKNPIP 2014	Catalog of Typical Flexible and Semi-Rigid Pavement Constructions (GDDKiA)
WT-2 2010	Asphalt pavements
WT-4 2010	Unbound mixtures
Maritime	
BS 6349-1-1	Maritime works, Part 1-1 – General - Code of practice for planning and design for operations
BS 6349-1-2	Maritime works, Part 1-2 – General - Code of practice for assessment of actions
BS 6349-1-3	Maritime works, Part 1-3 – General - Code of practice for geotechnical design
BS 6349-1-4	Maritime works, Part 1-4 – General - Code of practice for materials
BS 6349-2	Maritime works, Part 2 – Code of practice for design of quay walls, jetties and dolphins
BS 6349-4	Maritime works, Part 4 - Code of practice for design of fendering and mooring systems
BS 6349-5	Maritime works, Part 5 – Code of practice for dredging and land reclamation
PIANC WG180, 2014	Guidelines for Protecting Berthing Structures from Scour Caused by Ships
OCIMF	Mooring Equipment Guidelines
ILO CoP	Safety and Health in Ports, ILO Code of Practice, International Labour Organization, 2005, Geneva
Port Skills and Safety	Guidance (various)
PIANC WG33, 2002	Guidelines for the Design of Fender Systems
CIRIA C683, 2007	The Rock Manual. The Use of Rock in Hydraulic Engineering
PIANC Report No 121, 2014	Harbour Approach Channels, Design Guidelines
OCDI 2009	Technical Standards and Commentaries for Port and Harbour Facilities in Japan, 2009 (for guidance only)
Port Designer's Handbook	Carl A. Thoresen, Port Designer's Handbook 4th Edition, 2018
Surface Water Drainage	
PN-EN 12056-2:2002	Gravity Drainage Systems Inside Buildings-Part 2: Sanitary Pipework, Layout and Calculation
PN-92/B-10729	Sewerage – Sewer Wells
PN-92/B-10735	Sewerage – Sewerage Pipes – Requirements on Testing and Delivery
PN-85/C-89203	Sewer Fittings made of Non-Plasticised PVC
PN-85/C-89205	Sewer Pipes made of Non-Plasticised PVC
PN-87/B-01100	Mineral Aggregates, Rock Aggregates, Name, Breakdown and Terms
PN-B-10725;1997	Water Supply and External Pipes – Requirements and Testing
PN-B-10702	Water and Sewerage – Tanks - Requirements and Testing
Foul Drainage	
PN-EN 12056-2:2002	Gravity Drainage Systems Inside Buildings-Part 2: Sanitary Pipework, Layout and Calculation
PN-92/B-10729	Sewerage – Sewer Wells
PN-92/B-10735	Sewerage – Sewerage Pipes – Requirements on Testing and Delivery
PN-85/C-89203	Sewer Fittings made of Non-Plasticised PVC
PN-85/C-89205	Sewer Pipes made of Non-Plasticised PVC
PN-87/B-01100	Mineral Aggregates, Rock Aggregates, Name, Breakdown and Terms
PN-B-10725;1997	Water Supply and External Pipes – Requirements and Testing
PN-B-10702	Water and Sewerage – Tanks - Requirements and Testing

Potable Water System	
PN EN 805	Water Supply. Requirements for Systems and Components Outside Buildings
PN EN 1717	Protection Against Pollution of Potable Water in Water Installations and General Requirements of Devices to Prevent Pollution by Backflow
PN EN 12201	Plastics Piping Systems for Water Supply, and for Drainage and Sewerage Under Pressure. Polyethylene (PE)
Fire Water System	
PN-B-02852:2001	Fire protection of buildings: Calculation of fire load density
NFPA 307	Standard for the Construction and Fire Protection of Marine Terminals, Piers, and Wharves
PN-B-02863	Fire Protection in Construction. Fire-Fighting Water Supply. External Fire Water Supply Network with A Power Source and Arrangement of External Hydrants - Requirements
PN-B-02864	Fire Protection in Construction. Fire-Fighting Water Supply. Principles of Calculating the Water Demand for Fire-Fighting Purposes for External Firefighting
PN EN 12201	Plastics Piping Systems for Water Supply, and for Drainage and Sewerage Under Pressure. Polyethylene (PE)
-	The International Fire Code 2012 (International Code Council)
NFPA 10	Standard for Portable Fire Extinguishers
NFPA 13	Standard for the Installation of Sprinkler Systems
NFPA 14	Standard for the Installation of Standpipe and Hose Systems
NFPA 20	Standard for the Installation of Stationary Pumps for Fire Protection
NFPA 24	Standard for the Installation of Private Fire Service Mains and Their Appurtenances
PN-B-02852:2001	Fire protection of buildings: Calculation of fire load density
NFPA 307	Standard for the Construction and Fire Protection of Marine Terminals, Piers, and Wharves
PN-B-02863	Fire Protection in Construction. Fire-Fighting Water Supply. External Fire Water Supply Network with A Power Source and Arrangement of External Hydrants - Requirements
PN-B-02864	Fire Protection in Construction. Fire-Fighting Water Supply. Principles of Calculating the Water Demand for Fire-Fighting Purposes for External Firefighting
Electrical	
PN-E-90411	Extruded XLPE Cables Insulated from 3.6/6kV up to 18/30kV
PN-E-90400	Extruded PVC Cables insulated up to 3.6/6kV
PN-IEC 439-1	Low Voltage Switchgear and control gear assemblies
PN-12464-1	2003 (U) Internal Lighting of Interiors
PN-12464-2	Lighting of workplaces – Part 2: outdoor workplaces
PN-IEC-61024-1	Protection of Structures against Lightning
PN-EN 62305	Protection of Structures against Lightning
IEC 60364	Electrical installations of buildings
IEC 60034	Rotating Electrical Machines
IEC 60076	Power Transformers
IEC 60726	Dry Type Power Transformers
IEC 60529	Degrees of Protection Provided by Enclosure (IP Code)
IEC 60364	Electrical installations of buildings
IEC 61000	Electromagnetic Compatibility.

IEC 62040	UPS
IEC 62271-100	High-voltage switchgear and control gear - Part 100: High-voltage alternating current circuit-breakers
IEC 62271-200	High-voltage switchgear and control gear - Part 200: AC metal-enclosed switchgear and control gear for rated voltages above 1 kV and up to and including 52 kV
IEC 61984	Cables, trunking and ducting systems for electrical installations
IEC 60614	Conduits for electrical installations.
IEC 60214-1	Tap-changer – Part 1: Performance requirements and test methods.
IEC 60404	Magnetic Materials.
IEC 60751	Industrial platinum resistance thermometer sensors.
IEC 61869	Instrument transformers.
IEC 61439	Low-voltage switchgear and control gear assemblies.
IEC 60947	Low-voltage switchgear and control gear.
IEC/ISO/IEEE 80005	Cold ironing and shore supplies.
BS EN 62040-1	Uninterruptible power systems (UPS)
BS EN 1838	Lighting applications, emergency lighting
BS EN 54-1	Fire detection and alarm systems.
BS 7671	Wiring Regulations.
DIN EN 54-1:1996	Fire detection and fire alarm systems - Part 1: Introduction; German version EN 54-1:1996
DIN EN 60204-1:2000	Safety of machinery - Electrical equipment of machines - Part 1: General requirements (IEC 60204-1:1997 + Corrigendum 1998); German version EN 60204-1:1997
ISO 8528	Reciprocating internal combustion engine driven alternating current generating sets; part 1: application, ratings and performance - International Restrictions
ISO 1461-1999	Hot dip galvanized coatings on fabricated iron and steel articles - Employer's Requirements and test methods.
N SEP-E-007:2017-09	Electric power and telecommunication installations in buildings. Selection of cables to their reaction to fire.
Buildings	
Technical Condition	ORDINANCE MINISTER OF INFRASTRUCTURE of April 12, 2002 on the technical conditions to be met by buildings and their location Journal of Laws 2019.1065 of 2019.06.07
Fire Code	As defined in Part 6 Fire Protection condition – legal basis.
Cathodic Protection	
BS EN ISO 174:2012	CP for Harbour Installations.
ISO 12473:2014	General Principles of Cathodic Protection in Sea Water.
BS EN 12496: 2013	Galvanic Anodes for Cathodic Protection in Seawater and Saline Mud.
EN 12954: 2001	Cathodic Protection of Buried or Immersed Metallic Structures – General Principles and Applications for Pipelines.
EN 13509: 2003	Cathodic Protection Measurement Techniques.
Fuel Bunkering System	
API 5L	Specification for Line Pipe
API 2003	Protection Against Ignitions Arising Out of Static, Lightning, and Stray Currents
ASME B31.3	Process Piping Guide

ASME B31.4	Pipeline Transportation Systems for Liquids and Slurries
ASME B1.20.1	Pipe Threads, General Purpose, Inch
ASME B16.5	Pipe Flanges and Flanged Fittings: NPS 1/2 through NPS 24, Metric/Inch Standard
ASME B16.25	Buttwelding Ends
ASME B16.34	Valves - Flanged, Threaded, and Welding End
EMMUA 191	Alarm Management
IEC 60079-10-1	Explosive Atmospheres – Classification of Areas - Explosive Gas Atmospheres
IEC 60079-14	Explosive Atmospheres – Explosive Atmospheres Electrical Installations Design, Selection and Erection
IEC 61508	Functional Safety of Electrical / Electronic / Programmable Electronic (E/E/PE) Safety-Related Systems
IEC 61131	Programmable Controllers
ISO 12944	Paints and Varnishes
PN EN 124	Gully Tops and Manhole Tops for Vehicular and Pedestrian Areas
PN EN 6268	Management of Alarms Systems for the Process Industries
PN EN 14161	Pipeline Transportation Systems
PN EN 61511	Functional Safety. Safety Instrumented Systems for the Process Industry Sector
-	ATEX 95 Equipment Directive 94/9/EC
-	ATEX 137 Workplace Directive 99/92/EC
-	Energy Institute, Model of Safe Practice, Part 15: Area Classification for Installations Handling Flammable Fluids, 4th Edition 2015

2.5 Units, Levels, Datum and Co-ordinate Systems

Units, Levels, Datum and Co-ordinate Systems shall be in accordance with “Section 1 – General” of these Employer’s Requirements

2.6 Site Data

The following data is provided for information purposes only and the Contractor shall verify and update this data as appropriate (not older than 2020 data shall be used) for use in the design of the Works and advise any significant changes to be used in the design process for the Engineer’s approval.

Future changes to the climate and water level shall be considered.

Where other data is required for the Contractor’s design, for example rainfall and seismic data, the Contractor shall obtain relevant and current data, including any forecast changes to that data due to climate change, from Polish national or recognised international sources all of which shall be submitted to the Engineer for approval.

If the Design Vessels will be stopped in port in the storm weather the infrastructure (especially fenders, bollards and quay structure) shall be not damaged by the ship along the berth up to a wind speed of 140 km/h

2.6.1 Water Levels

The water levels recorded between 2006 and 2020 are as follows (Table 2-2):

Table 2-2: Characteristic states - Gdansk Port Polnocny (Poland) water gauge from 2006-2020

Description	Water Level relative mKR	Water Level relative to MSL	Water Level relative to mEV
The biggest water ever - High Water Level (WWW) in 15 years	1.33	1.30	1.41
The mean from 15 years of the Highest Water Level (SWW)	0.95	0.92	1.03
The upper limit of the mean water level	0.34	0.31	0.42
The mean from 15 years of the Mean Water Level (SSW)	0.03	0.00	0.11
The lower limit of the mean water level	-0.27	-0.30	-0.19
The mean from 15 years of the Low Water Level (SNW)	-0.61	-0.64	-0.53
The lowest water ever - Low Water Level (NNW) in 15 years	-1.04	-1.07	-0.96

The maximum (positive) and minimum (negative) water levels having specific probabilities of occurrence are given in Table 2-3 and Table 2-4 below. These are based on research in 2009 (high water) and 1992 (low water).

Table 2-3 – Probabilities of occurrence and return periods of the positive water levels in Gdansk (Source: Wiśniewski & Wolski, 2009)

Probability (% Frequency)	Period (Years)	Water Level relative to MSL	Water Level relative to mEV
99	1	0.38	0.49
20	5	1.06	1.17
10	10	1.20	1.31
5	20	1.33	1.44
2	50	1.49	1.60
1	100	1.60	1.71
0.5	200	1.71	1.82
0.1	1000	1.95	2.06

* Note: 1 year value is based on Wroblewski, 1992 data

Table 2-4 – Probabilities of occurrence and return periods of the negative water levels in Gdansk (Wroblewski, 1992)

Probability (% Frequency)	Period (Years)	Water Level relative to MSL (m)	Water Level relative to mEV
99	1	-0.36	-0.25
20	5	-0.73	-0.62
10	10	-0.80	-0.69
5	20	-0.87	-0.76

2	50	-0.94	-0.83
1	100	-1.00	-0.89
0.5	200	n/a	n/a
0.1	1000	-1.16	-1.05

2.6.2 Sea Level Rise

A minimum allowance for sea level rise of 3.3mm/year, for the defined design life, shall be considered in the design of the Works.

2.6.3 Tidal Lag

For the design of earth retaining structures, tidal lag shall be considered in accordance with BS6349-1-3-2021 or similar approved design codes of practice. The effects of permeability of the reclamation fill behind retained structures shall be considered when designing for tidal lag. However, a minimum of 0.5m shall be considered at all times in the design.

2.6.4 Waves

The 1 in 1 year and 1 in 100-year return period wave conditions to be considered in the design are summarised in Table 2-5 below:

Table 2-5 – Wave conditions

Structure Location	Return Period (years)	Design Water Level (m MSL)	Design Water Level (m Kr)	Design Wave Height, Hm0 (m)	Peak Wave Period, Tp (s)
OWSB Outbound	1 year	+0.628 ^(*)	+0.738*	1.2	10
	100 years	+1.848 ^(*)	+1.958*	2.0	11
OWSB Inbound / Ro-Ro Berth	1 year	+0.628 ^(*)	+0.738*	1.2	10
	100 years	+1.848 ^(*)	+1.958*	2.0	11

(*) Includes 75 years sea level rise.

The terminal shall be designed to withstand waves of up to 1 in 100-year return period and remain operational in a 1 in 1 year return wave height.

2.6.5 Wind

Structures shall be designed to the wind speeds given in the specified design standard and methods appropriate for the structure under consideration in coastal areas on flat terrain. No wind shielding will be allowed for in the design of structures.

Consideration shall be given in the design for wind fluctuations with time (wind buffeting and gust allowance), for not only the wind effects on external structure surfaces, but also the wind effects on the internal surface of all structures, i.e., with access doors open.

The frequency of wind conditions is presented in Table 2-6 below.

Table 2-6 – Frequency of winds in % for all directions 2012-2022

Uw (m/s)	Directional Sector (deg N)																Classes %
	0.0	22.5	45.0	67.5	90.0	112.5	135.0	157.5	180.0	202.5	225.0	247.5	270.0	292.5	315.0	337.5	
0-1	0.08	0.09	0.08	0.07	0.06	0.07	0.05	0.07	0.07	0.09	0.09	0.09	0.08	0.07	0.10	0.08	1.22
1-2	0.35	0.36	0.32	0.33	0.28	0.30	0.30	0.29	0.34	0.37	0.39	0.41	0.37	0.30	0.34	0.33	5.37
2-3	0.59	0.63	0.69	0.67	0.70	0.64	0.73	0.82	0.73	0.80	0.81	0.83	0.74	0.73	0.65	0.57	11.32
3-4	0.85	0.74	0.85	0.83	0.85	0.87	0.92	1.05	1.12	1.08	1.24	1.24	1.39	0.99	0.83	0.84	15.68
4-5	0.72	0.77	0.87	0.77	0.71	0.87	1.00	1.20	1.24	1.28	1.43	1.68	1.71	1.33	0.95	0.70	17.22
5-6	0.53	0.70	0.66	0.55	0.52	0.67	1.06	1.11	1.20	1.28	1.36	1.73	1.78	1.18	0.85	0.66	15.84
6-7	0.38	0.51	0.42	0.36	0.38	0.50	0.80	0.88	1.08	1.09	1.19	1.47	1.54	1.12	0.67	0.52	12.91
7-8	0.37	0.28	0.21	0.18	0.22	0.30	0.38	0.50	0.78	0.65	0.83	1.15	1.26	0.92	0.47	0.35	8.84
8-9	0.18	0.16	0.08	0.09	0.09	0.16	0.22	0.27	0.36	0.32	0.47	0.70	0.93	0.67	0.32	0.25	5.27
9-10	0.09	0.09	0.07	0.05	0.04	0.07	0.13	0.13	0.19	0.16	0.25	0.52	0.66	0.38	0.16	0.18	3.16
10-11	0.05	0.05	0.05	0.01	0.02	0.01	0.01	0.04	0.05	0.06	0.11	0.25	0.42	0.24	0.13	0.11	1.61
11-12	0.02	0.02	0.01	0.00	0.01	0.00	0.00	0.01	0.04	0.02	0.03	0.11	0.23	0.14	0.07	0.06	0.78
12-13	0.01	0.02	0.01	0.00	-	-	-	0.01	0.01	0.02	0.01	0.04	0.12	0.09	0.03	0.05	0.42
13-14	0.00	0.01	0.01	-	-	-	-	-	-	0.01	0.00	0.03	0.06	0.04	0.01	0.03	0.20
14-15	0.00	0.00	0.00	-	-	-	-	-	-	-	0.01	0.01	0.05	0.02	0.01	0.02	0.12
15-16	-	-	-	-	-	-	-	-	-	-	-	0.00	0.02	0.01	0.00	-	0.04
16-17	-	-	-	-	-	-	-	-	-	-	-	-	0.01	0.00	-	-	0.01
17-18	-	-	-	-	-	-	-	-	-	-	-	-	0.00	0.00	-	-	0.00
Total%	4.21	4.42	4.32	3.91	3.88	4.47	5.61	6.37	7.19	7.23	8.22	10.27	11.38	8.24	5.58	4.73	100.00

All year

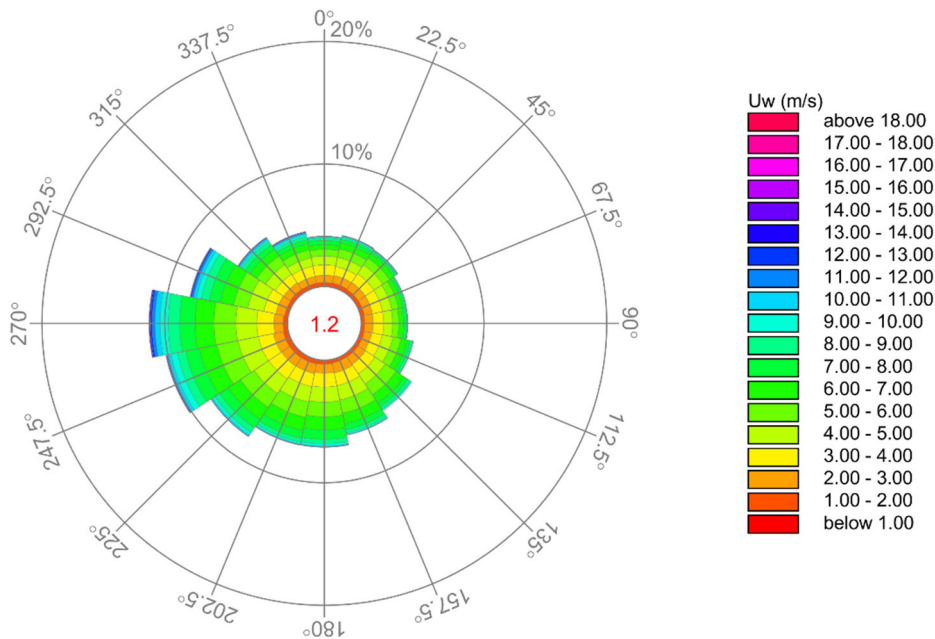

The design for the T5 terminal shall allow operations (inc. berthing and mooring) to continue up to gust wind speeds of 72km/h, or 20m/s.

For the tower packs, 1 in 10-year wind speed will be used for the calculation of the ground bearing pressure in accordance with EN 1991-1-4, wind acting in any direction.

2.6.6 Sea Ice

Ice field pressures on marine structures are not required be considered in the design.

Although ice exists on average for approximately 14 days per year between December to March, ice fields do not exist in the harbour area due to ice breaking works.

2.6.7 Temperature

The extreme temperature ranges at Gdansk are presented below (Table 2-7):

Table 2-7 – Gdansk temperature extremes

Range	Shade Temperature (°C)
Maximum	+35
Minimum	-25

2.6.8 Bathymetric Surveys

Historic bathymetric data is available in the vicinity of the T5 terminal footprint, in addition to dredging plans for the T1 and T3 terminals.

A recent bathymetric survey, undertaken in October 2023, of the T5 footprint area has been undertaken. The results of this survey are also available.

The Contractor shall review the available bathymetric survey data and the Contractor shall determine suitability of information and carry out additional surveys if required.

Where required, to infill gaps and provide data outside the port for numerical modelling, bathymetry will be obtained by the Contractor in accordance with the Employer's Requirements.

2.6.8.1 Ground Conditions

The following geotechnical information is available:

- Northern port - modernization of the approach fairway and island breakwater
 - Budowa geologiczna dna w rejonie toru podejściowego do Portu Północnego - Państwowy Instytut Geologiczny (March, 2012)
- Geology of T1
 - Dokumentacja geologiczno-inżynierska do rozpoznania warunków geologiczno-inżynierskich pod budowę terminalu kontenerowego w Porcie Północnym, Gdańsk - Państwowy Instytut Geologiczny (January, 2005)
- Geotechnical Investigations
 - Documentation of the Geotechnical Investigations Volume 1
 - Documentation of the Geotechnical Investigations - Laboratory Test Report -Volume 2
 - Report on Bottom Sediment Pollution Testing – Volume 3
- Geotechnical Interpretation report
 - DCT Gdansk Terminal Expansion – Geotechnical Interpretation Report
- Geotechnical Investigations for T3
 - Volume 1: Documentation of the geotechnical investigations of T3 by INGEO 2020

- Volume 2: Laboratory Test Results Report by INGEO 2020
- Volume 3: Chemical testing Results Report by INGEO 2020
- Geotechnical Investigations for T5
 - DBPG-74-2022_Documentation of subsoil investigation 2023
 - OG-74-2022_Geotechnical opinion 2023

2.6.9 Seismic Design

The Contractor shall carry out their own seismic risk assessment to determine the seismic design conditions for the Works. The scope of the study shall be approved by the Engineer.

2.7 Quay and Retaining Wall Structures

The design of the quay and retaining wall structures shall be predominantly for the OWSB T5 operations and design vessels. However, as mentioned in Section 1 of these Employer's Requirements, the quay and retaining wall structures constructed initially for the OWSB will be eventually utilised as a container terminal. Therefore, as part of the design the Contractor must take into consideration the additional loads and requirements of the future container terminal operations and design container vessels.

In this section of the Design Criteria, both the OWSB and container design vessels and quay requirements are provided. The Contractor shall assess both sets of the design parameters and design his quay and retaining wall structures to the most onerous set of design requirements and parameters.

2.7.1 OWSB Outbound Berth / Future Container Berth

2.7.1.1 Design Vessels

Table 2-8 below presents the basic parameters of the OWSB vessels for the OWSB Outbound Berth.

Table 2-8 Design OWSB WIV vessel parameters

Vessel	Length (m)	Beam (m)	Draft (m)	DWT
Aeolus	139.4	44.46	8.6	11,990
MPI Adventure	138.55	40.8	5.5	6,000
MPI Resolution	130	38	4.3	5,000
Taillevent	138.55	40.8	5.22	20,739
Voltaire	169.3	60	7.5	21,500
Vole au Vent	169.3	60	7.5	8,265

Table 2-9 below presents the basic parameters of the container vessels for the OWSB Outbound Berth.

Table 2-9 – Design container vessel parameters

Characteristics	Unit	Minimum vessel	Maximum vessel (A)	Maximum vessel (B)
Deadweight tonnage	DWT	1,000	250,000	250,000
Displacement, M	t	1,600	325,000	325,000
Overall length, L _{OA}	m	59	470	450
Perpendiculars length, L _{BP}	m	56.4	450	430
Beam, B	m	13	61.5	64
Depth, D	m	4.5	35	35
Maximum draught, T _{full}	m	3	16	16

2.7.1.2 Berthing Parameters

Fenders for the container and OWSB operations shall be designed for the full range of design vessel characteristics and berthing parameters below.

The fender system shall cater for both the OWSB and container operations (i.e fender type, spacing etc. will be consistent across both operations)

It is to be noted that the 15m maximum fender spacing is driven by the Container Berth requirements. Given the shape of the hull of the OWSB design vessels are significantly different to container design vessels, it may be necessary to place fenders at a much closer spacing than the 15m (To be determined by the Contractor through a berthing and mooring analysis).

Berthing parameters are specified in Table 2-10 below for the future container vessels.

Table 2-10 – Berthing parameters for container vessels

Design Parameter	Design Value
Berthing Mode	Quarter point or for a point of contact determined from the hull geometry and berthing angle, whichever gives the worst case.
Transverse Approach Velocity	Berthing condition: Operational: 0.15m/s;
Design berthing energy	Berthing energy factor of 1.5 to be used for all vessels in accordance to BS 6349-4
Berthing Angle	Up to 4,000DWT = 15° 4,000 - 25,000DWT = 10° 25,000 - 250,000DWT = 6°
Fender spacing (CL to CL)	Maximum spacing of 15.0m (Spacing to be confirmed by the Contractor through a vessel berthing and mooring analysis)
Low friction panel surfacing	Low friction fender panel facing UHMW-PE to be used. Coefficient of friction of UHMW-PE to steel not less than 0.5 (for structural design)
Bow flare angle	15 degrees (vertically)
Rolling of vessel	3 degrees (vertically)
Allowable hull pressure	200kN/m ²
Fender panel requirement	Fender panel not to extend above the cope level.

	Chamfers to be provided on four sides of the panel. Fender panel in one piece - assembly of the steel panel from several elements is not allowed.
Chains between quay and fender (to prevent rope snagging)	Required
Factor of safety on restraint chains and fixings	3.0
Maximum hull clearance	300mm
Correction Factors	Velocity, temperature, angle and tolerance correction factor to be taken into consideration

Berthing parameters are specified in Table 2-11 below for the OWSB vessels.

Table 2-11 – Berthing parameters for OWSB vessels

Design Parameter	Design Value
Berthing Mode	Quarter point or for a point of contact determined from the hull geometry and berthing angle, whichever gives the worst case
Transverse Approach Velocity	Berthing condition: Operational: 0.15 m/s;
Design berthing energy	Berthing energy factor of 1.5 to be used for all vessels in accordance to BS 6349-4
Berthing Angle	< 5°
Fender spacing (CL to CL)	Maximum spacing of 15.0m (Spacing to be confirmed by the Contractor through a vessel berthing and mooring analysis)
Low friction panel surfacing	Low friction fender panel facing UHMW-PE to be used. Coefficient of friction of UHMW-PE to steel not less than 0.5 (for structural design)
Bow flare angle	10 degrees
Rolling of vessel	3 degrees (vertically)
Allowable hull pressure	200kN/m ²
Fender Type	Cone Fender (Trelleborg or similar approved by the Employer)
Fender panel requirement	Fender panel not to extend above the cope level. Chamfers to be provided on four sides of the panel. Fender panel in one piece - assembly of the steel panel from several elements is not allowed.
Chains between quay and fender (to prevent rope snagging)	Required
Factor of safety on restraint chains and fixings	3.0
Maximum hull clearance	300mm
Correction Factors	Velocity, temperature, angle and tolerance correction factor to be taken into consideration

A suitable fender system shall be selected to absorb the design berthing energy. The fender design reaction force and energy shall consider the following:

- Manufacturer’s tolerances
- Velocity factors as suggested by the manufacturer.
- Temperature factors as suggested by the manufacturer.

- Angular performance due to bow flare, bow radius and berthing angle.
- Energy sharing between fenders may be considered depending on the vessel geometry.
- Specifically for the OWSB design vessels, the berthing energy shall be increased by 10% to take into consideration future generation of offshore wind installation vessels.

2.7.1.3 Quay Geometry

Table 2-12 below presents the quay geometry parameters.

Table 2-12 – Quay geometry

Design parameter	Container Berth Design Value	OWSB Berth Design Value
Quay cope level (m Kr)	+3.0m Kr (+3.08m EV)	As per container berth
Dredge depth alongside berth (m Kr) (top of scour protection and rock blanket – if required)	Not less than -17.50m Kr (-17.42 EV)	As per container berth
Technical depth alongside berth (m KR) maximum depth at which the quay wall will function and remaining stable after dredging tolerance and scour	-19.0m Kr -18.92m EV	As per container berth
Berth length (m)	451m	As per container berth
Berthing line to quay edge distance (m)	2.5m	As per container berth
Quay edge to front crane rail CL (m)	6.0m	Not required for OWSB. However, provision to be made to provide required infrastructure to install the rails at a future date.
STS crane rail gauge (m)	35.0m	Not required for OWSB. However, provision to be made to provide required infrastructure to install the rails at a future date.
Level difference between STS rails	Land side rail can be a maximum of 35cm lower. Both rails shall tie in with T1 rail levels	Not required for OWSB. However, provision to be made to provide required infrastructure to install the rails at a future date.
Hatch cover area width	20.5m (including safety offset from landside crane rail)	Not required for OWSB. However, provision to be made to ensure quay wall can accommodate when converted to a container terminal.

2.7.1.4 Mooring Equipment

Table 2-13 below outlines the mooring equipment requirements.

Table 2-13 – Mooring equipment

Design Parameter	Container Berth Design Value	OWSB Berth Design Value
Bollard type	Any proprietary manufactured bollard capable of accommodating two adjacent vessels and subject to approval by the Employer	As per container berth
Bollard capacity	200 tonne (To be confirmed by the Contractor through a vessel berthing and mooring analysis)	Minimum 100 tonne but the bollards shall be the more onerous between the container or OWSB terminal (To be confirmed by the Contractor through a vessel berthing and mooring analysis)
Maximum spacing and layout	Maximum spacing of 15.0m - equal distances between the bollards (Spacing to be confirmed by the Contractor through a vessel berthing and mooring analysis)	As per container berth
Removable bollards	Not required	Contractor to investigate the possibility of installing removable bollards

2.7.1.5 Quay Equipment and Layout

Table 2-14 below outlines the quay equipment requirements.

Table 2-14 – Quay equipment and layout

Design Parameter	Container Berth Design Value	OWSB Outbound Berth Design Value
Safety ladders and handgrips	Not more than 30m centres Ladders to extend 1m below design low water level. Ladders are to be recessed so as not to protrude beyond the cope line and protect by vertical bollards to allow safe evacuation. Handgrips shall be provided at deck level in a way to avoid ropes snagging	As per container berth
Handhold (either safety ladders or safety chains)	Not more than 15m centres – equal distances between	As per container berth
Navigation aids	Yellow pulsing navigation lights to be provided at either end of the quay	As per container berth
Cold ironing pits	6 nr evenly distributed locations along the quay as shown indicatively on the Drawings	As per container berth
Electrical Installation Wells	4 nr along the quay as shown indicatively on the Drawings	As per container berth
Potable water intake points	4 nr at 100m centres along the quay as shown indicatively on the Drawings	As per container berth

Berthing aid system (BAS)	3nr speed of approach measurement lasers 2 Nr display boards to be provided as shown indicatively on the Drawings	As per container berth
---------------------------	--	------------------------

2.7.1.6 Design Imposed Loads – Outbound OWSB Operations

The OWSB Outbound Berth structures shall be subject to the maximum superimposed loads in the vicinity of the Berth as specified in Section 2.9. The footprint of areas in the OWSB in which the various imposed loads could be located/positioned are shown on the Drawings.

These loads shall be in addition to environmental, berthing, and mooring loads.

2.7.1.7 Design Imposed Loads– Container Operations

Seaward of the Front Crane Rail

To accommodate the future Container Terminal, the OWSB Outbound Berth shall be designed to carry the following superimposed loads seaward of the front crane rail, in addition to environmental, berthing and mooring loads:

- Vehicles with a maximum load of 115 kN/axle
- 20kPa surcharge

Landward of the Front Crane Rail

To accommodate the future Container Terminal, the OWSB Outbound Berth shall be designed to carry the following superimposed loads landward of the front crane rail, in addition to environmental, berthing and mooring loads:

- 40kPa surcharge
- Terminal Tractors / Internal Movement Vehicles (As described in Section 2.7.1.8)
- 3 high stacked laden containers in blocks.

2.7.1.8 Terminal Tractors / Internal Movement Vehicles

Wheel arrangements for terminal tractors / internal movement vehicle (IMV) are as shown below in Figure 2-1 and

Table 2-15.

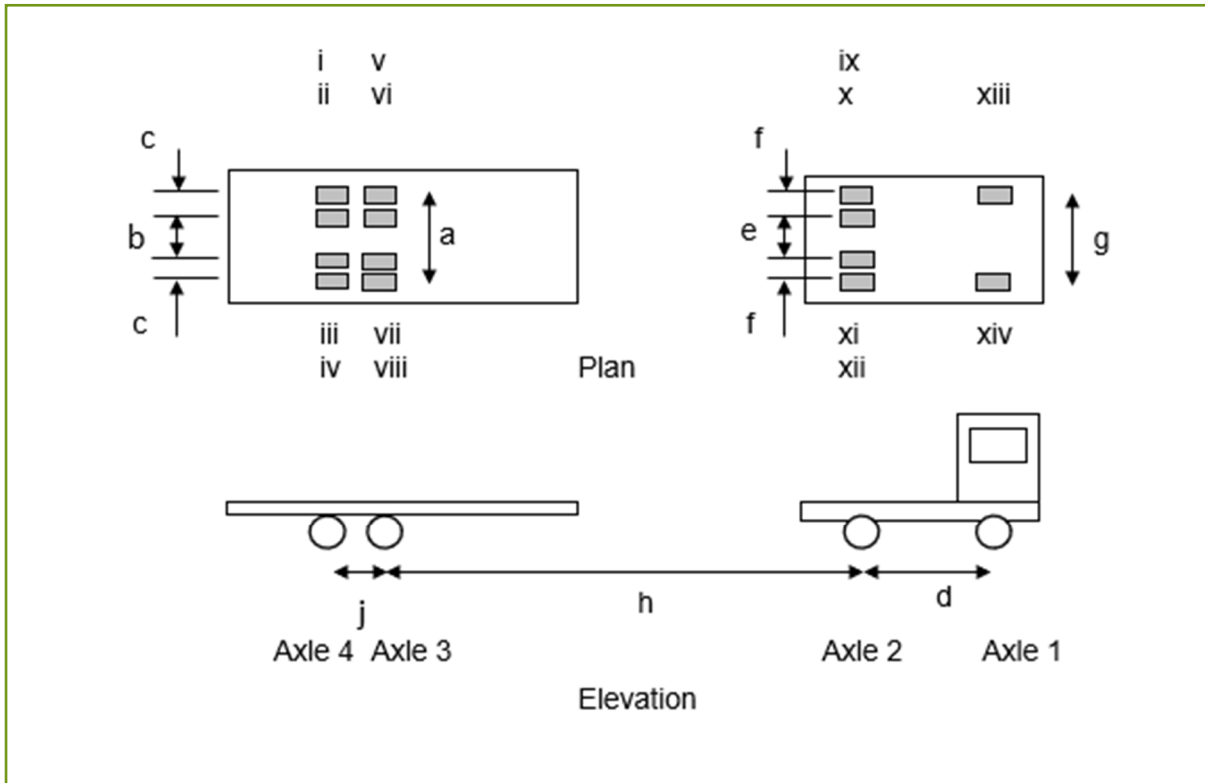

Figure 2-1 Wheel arrangement for terminal tractors / IMVs

Table 2-15 Dimensions of terminal tractors / IMVs

Dimension	a	b	c	d	e	f	g	h	j
Value (mm)	2600	1000	800	2900	1400	400	2200	10000	1200

Table 2-16 below summarises the axle loads to be assumed for the terminal tractors / IMVs.

Table 2-16 Terminal tractor/IMV axle loads

Load Condition	Weight Distribution (kN)			
	1	2	3	4
30.5t	49	150	136	136
41t	49	181	167	167
60t	49	250	235	235

The following dynamic factors identified in the BPA Manual, Table 17 shall be adopted:

- Braking / accelerating: 10%
- Cornering: 30%
- Total dynamic: 40%

2.7.2 Seabed Reinforcement for WIV Jack Up Operations

The Contractor shall assess and provide an alternative design solution for seabed reinforcement over the main T5 outbound berth pocket. Where necessary, provision of a reinforced seabed/stone bed will be designed for the main T5 outbound quay to remove soil risk and avoid operational limitation so that the jack up spud legs do not penetrate into the native seabed soil by more than 1m. As a minimum the stone bed shall match the spud can positions, and the ground bearing pressure of 100t/m² shall be considered for the assessment and design. The Contractor shall provide a provisional sum in the Pricing Schedule to cover for the option of installing the rock protection over the Outbound Quay Berthing area.

Should seabed reinforcement be required, the top level of the reinforcement cannot be higher than – 17.42mEV. The removal of any seabed material will need to be considered when constructing and installing the rock mattress.

2.7.3 OWSB Inbound Berth

2.7.3.1 Design Vessels

Table 2-17 below presents the basic parameters of the design OWSB vessels for the OWSB Inbound Berth.

Table 2-17 – OWSB inbound berth design vessels

Vessel	Length (m)	Beam (m)	Draft (m)	DWT
BBC Citrine	153.47	23.2	9.1	14,387
Boldwind	148.45	28.042	5.6	10,000
Bravewind	148.428	28.032	5.6	10,000
Rotra Vente	141.52	21.4	7.05	8,929
Symphony Sun	122.5	17.05	7.81	10,546
Vestvind	130	24.99	5.216	10,238
Rotra Mare	141.6	25.6	7.72	8,818

When the terminal reverts to a container terminal, the OWSB Inbound berth will not accept vessels. Therefore, the berth does not need to be designed for container vessels.

2.7.3.2 Berthing Parameters

Fenders for the OWSB inbound operations shall be designed for the full range of design vessel characteristics and berthing parameters below.

Table 2-18 – Berthing parameters for OWSB inbound vessels

Design Parameter	Design Value
Berthing Mode	Quarter point or for a point of contact determined from the hull geometry and berthing angle, whichever gives the worst case.
Transverse Approach Velocity	To be determined by the Contractor with reference to BS6349-4 (section 5.2.2)
Design berthing energy	Berthing energy factor of 1.5 to be used for all vessels in accordance to BS 6349-4
Berthing Angle	Up to 10°
Fender spacing (CL to CL)	To be determined by the Contractor through a vessel berthing and mooring analysis

Bow flare angle	10 degrees (vertically)
Rolling of vessel	3 degrees (vertically)
Allowable hull pressure	<300kN/m ² (to be verified by the Contractor)
Fender Type	Cone Fenders under building permit. Contractor to decide if alternatives are suitable

A suitable fender system shall be selected to absorb the design berthing energy. The fender design reaction force and energy shall consider the following:

- Manufacturer's tolerances
- Velocity factors as suggested by the manufacturer
- Temperature factors as suggested by the manufacturer
- Angular performance due to bow flare, bow radius and berthing angle
- Energy sharing between fenders may be considered depending on the vessel geometry

2.7.3.3 Quay Geometry

Table 2-19 below presents the quay geometry parameters.

Table 2-19 – Quay geometry

Design parameter	OWSB Berth Design Value
Quay cope level (m Kr)	+3.00m Kr (+3.08mEV)
Dredge depth alongside berth (m Kr) (top of scour protection – if required)	-17.50m Kr (-17.42mEV)
Berth length (m)	349m
Berthing line to quay edge distance (m)	Minimum 2m

2.7.3.4 Mooring Equipment

Table 2-20 below outlines the mooring equipment requirements.

Table 2-20 – Mooring equipment

Design Parameter	OWSB Berth Design Value
Bollard type	Any proprietary manufactured bollard capable of accommodating design vessels and subject to approval by the Employer
Bollard capacity	To be determined by the Contractor through a vessel berthing and mooring analysis
Maximum spacing and layout	To be determined by the Contractor through a vessel berthing and mooring analysis

2.7.3.5 Quay Equipment and Layout

Table 2-21 below outlines the berth equipment requirements.

Table 2-21 – Quay equipment and layout

Design Parameter	Design Value
Safety ladders and handgrips	<p>Not more than 30m centres</p> <p>Ladders to extend 1m below design low water level</p> <p>Ladders are to be recessed so as not to protrude beyond the cope line and protect by vertical bollards to allow safe evacuation</p> <p>Handgrips shall be provided at deck level in a way to avoid ropes snagging</p>
Handhold (either safety ladders or safety chains)	Not more than 15m centres – equal distances between
Navigation aids	Yellow pulsing navigation lights to be provided at either end of the quay

2.7.3.6 Imposed Loads – OWSB Inbound Operations

The OWSB Inbound Berth structures shall be subject to the maximum superimposed loads in the vicinity of the Berth as specified in Section 2.9. The footprint of areas in the OWSB in which the various imposed loads could be located/positioned are shown on the Drawings.

These loads shall be in addition to environmental, berthing, and mooring loads.

2.7.3.7 Design Imposed Loads– Container Operations

To accommodate the future Container Terminal, the OWSB Inbound Berth shall be designed to carry the following superimposed loads, in addition to environmental, berthing and mooring loads:

- Within 20m of the quay edge:
 - Terminal Tractors / IMV (as described in Section 2.7.1.8)
 - Unladen Reach Stacker (as described in Section 2.7.3.8)
 - Unladen Empty Container Handler (as described in Section 2.7.3.9)
 - Forklift Truck (as described in Section 2.7.3.10)
 - Container Terminal Mobile Crane (as described in Section 2.7.3.11)
 - Snow Plough
- 20m landward from the quay edge:
 - As above (same as within 20m of quay edge)
 - 6 high laden and 10 wide container stacking

2.7.3.8 Reach Stacker

The Reach Stacker is based on a Kalmar DRG450-75S6HXSE. This shall be verified by the Contractor to ensure it provides the most onerous reach stacker loading to the berth structures.

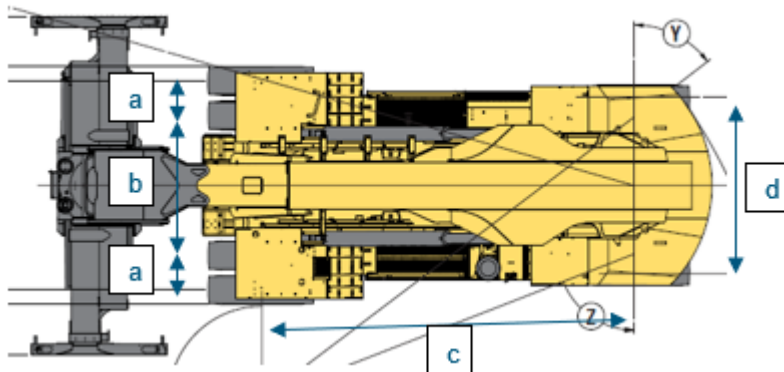

Dimension	Tyre group width, a	Front axle Inner tyre c/c, b	Wheelbase, c	Rear track width, d
Value (mm)	663	2,367	7,500	2,800

	Reach Stacker
Lift capacity	46t
Service weight	86.4t
No. wheels front/rear	4/2
Un-laden front / rear axle load	46t / 41.3t
Maximum laden front / rear axle load	122.3t / 12.8t

The following dynamic factors identified in the BPA Manual, Table 17 shall be adopted:

- Braking: 30%
- Cornering: 40%
- Acceleration: 10%
- Uneven surface: 20%

2.7.3.9 Empty Container Handler

The berth structures design shall take account of loading by an Empty Container Handler (ECH) loads as per the figure below (based on a Kalmar DGG90-45ED8/7). This shall be verified by the Contractor to ensure it provides the most onerous ECH loading to the berth structures.

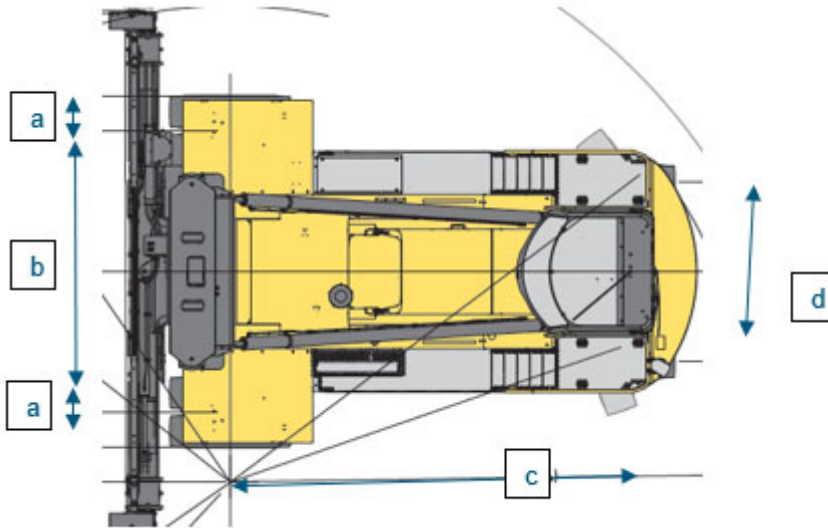

Dimension	Tyre group width, a	Front axle Inner tyre c/c, b	Wheelbase, c	Rear track width, d
Value (mm)	600	2307	4550	2400

Aspect	Empty Container Handler	Notes
Lift capacity	9t	
Service weight	42.6t	
No. wheels front/rear	4 / 2	
Laden front / rear axle load	42.7t / 8.9t	Consistent with 9 tonne lift
Un-laden front / rear axle load	28.8t / 13.8t	

The following dynamic factors identified in the BPA Manual, Table 17 shall be adopted:

- Braking: 30%
- Cornering: 40%

- Acceleration: 10%
- Uneven surface: 20%

2.7.3.10 Forklift Trucks

The berth structures design shall take account of loading by a The Forklift Truck (FLT) with a 16t lift capacity. This is based on a Konecranes SMV 16-600C. This shall be verified by the Contractor to ensure it provides the most onerous FLT loading to the berth structures.

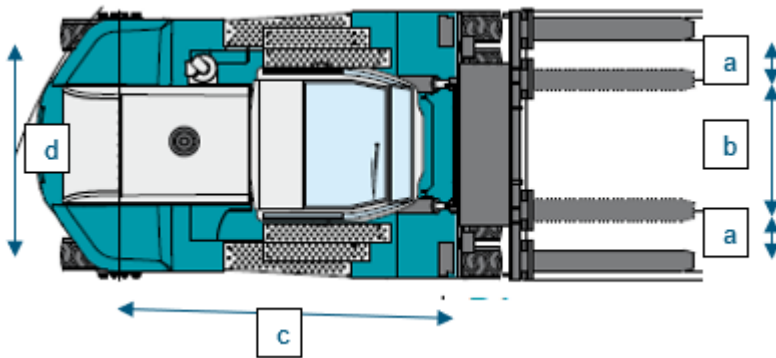

Dimension	Tyre group width, a	Front axle Inner tyre c/c, b	Wheelbase, c	Rear track width, d
Value (mm)	691	1554	3500	2036

Aspect	Value	Notes
Lift capacity	16t	
Service weight	19.5t	
No. wheels front/rear	4 / 2	
Laden front / rear axle load	33.5t / 2.0t	Consistent with 16 tonne lift
Un-laden front / rear axle load	10.5t / 9t	

The following dynamic factors identified in the BPA Manual, Table 17 shall be adopted:

- Braking: 30%
- Cornering: 40%
- Acceleration: 10%

- Uneven surface: 20%

2.7.3.11 Container Terminal Mobile Crane

The berth structures design shall take account of loading by a 35 tonne mobile crane used primarily for maintenance activities. The mobile crane used shall be equivalent to an LTM 1030-2.1. Details of the associated wheel loads are provided below. This shall be verified by the Contractor to ensure it provides the most onerous FLT loading to the berth structures.

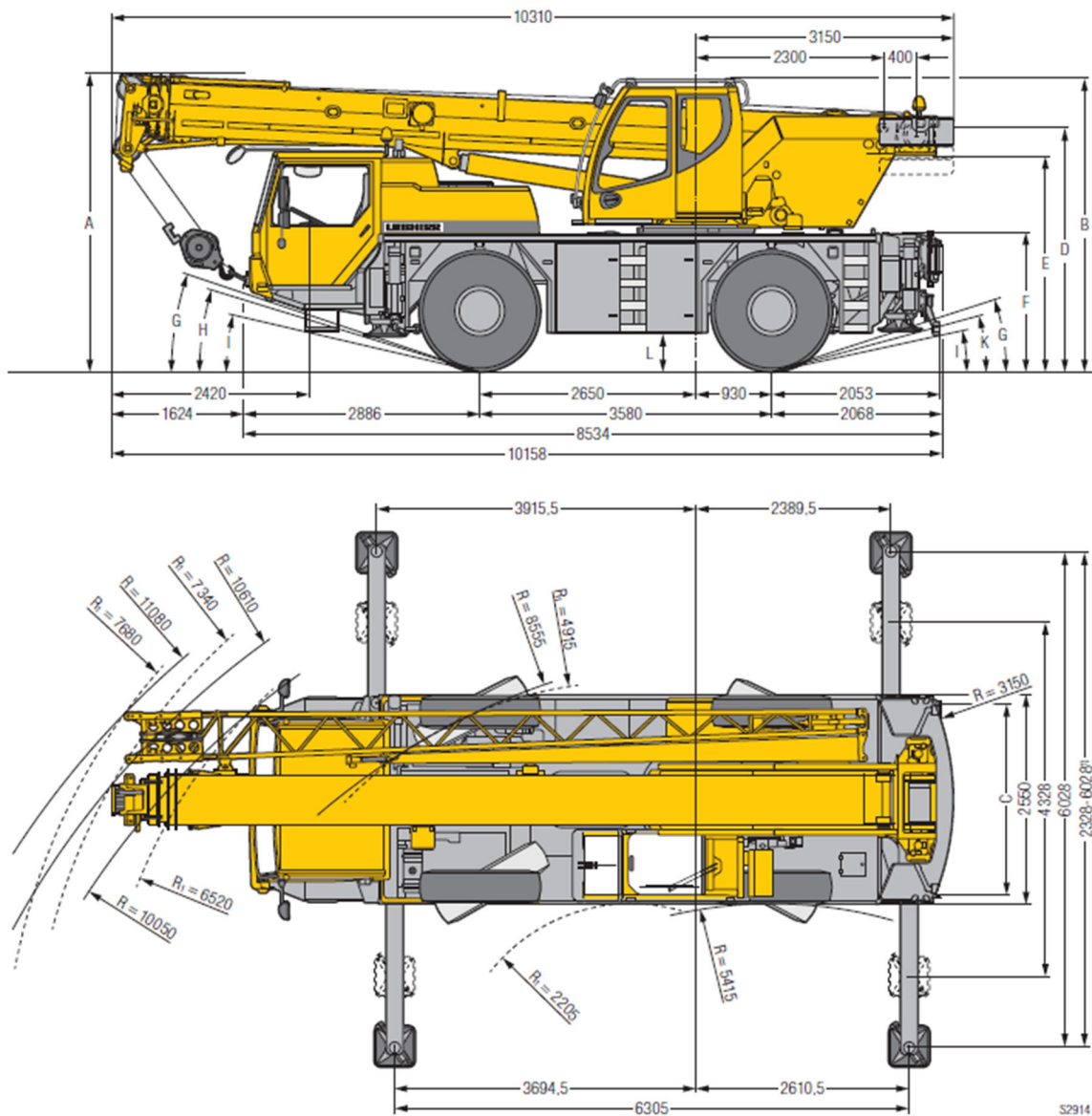

Dimension	Front axle width, a	Rear axle width, b	Wheelbase length, c
Value (mm)	2100	2100	3580

Load Condition	Front Axle	Rear Axle
Transit	12	12

The following dynamic factors identified in the BPA Manual, Table 17 shall be adopted:

- Braking: +10% (front wheel), -10% (rear wheels)

2.7.4 OWSB RoRo Berth

The OWSB Ro-Ro berth shall be designed and constructed as a series of breasting and mooring piled dolphin structures in the location as shown on the drawings (subject to verification through a berthing and mooring analysis by the Contractor).

2.7.4.1 Design Vessels

Table 2-22 below presents the basic parameters of the OWSB design vessels for the OWSB RoRo Berth.

Table 2-22 Design OWSB vessel parameters

Vessel	Length (m)	Beam (m)	Draft (m)	DWT	Stern Ramp (m)
Roll Dock – S Class	142.0	24.00	5.9	7,000	19.0 x 9.5
Roll Dock – ST Class	151.50	25.40	5.9	9,000	19.4 x 9.5

When the terminal reverts to a container terminal, the OWSB RoRo berth will not accept vessels. Therefore, the berth does not need to be designed for container vessels.

2.7.4.2 Berthing Parameters

Fenders for the OWSB operations shall be designed for the full range of design vessel characteristics and berthing parameters below

Table 2-23 – Berthing parameters for OWSB vessels

Design Parameter	Design Value
Berthing Mode	The berthing mode will either be direct longitudinal approach to berth end-on to shore ramp using breasting dolphins as a guide or parallel approach to a row of dolphins and after coming to rest, move slowly longitudinally to berth end on to shore ramps.
Transverse Approach Velocity	To be determined by the Contractor with reference to BS6349-4 (section 5.2.2)
Design berthing energy	Berthing energy factor of 1.5 to be used for all vessels in accordance to BS 6349-4
Berthing Angle	Up to 10° (Contractor is to verify based on review of design vessels' hull geometry)
Fender/dolphin spacing (CL to CL)	As per the drawings. However, specified spacing shall be verified by the Contractor through a berthing and mooring analysis
Bow flare angle	15 degrees (vertically)
Rolling of vessel	3 degrees (vertically)
Allowable hull pressure	200kN/m ²
Fender Type	Cone or Pneumatic Fenders -must be designed so that the dolphins are protected from all angles of approach.

A suitable fender system shall be selected to absorb the design berthing energy. The fender design reaction force and energy shall consider the following:

- Manufacturer's tolerances
- Velocity factors as suggested by the manufacturer
- Temperature factors as suggested by the manufacturer
- Angular performance due to bow flare, bow radius and berthing angle
- Energy sharing between fenders may be considered depending on the vessel geometry

Mooring and berthing will be provided by dolphin structures which shall be design in accordance with BS 6349-Part 4 with the layout typically as show in the figure below:

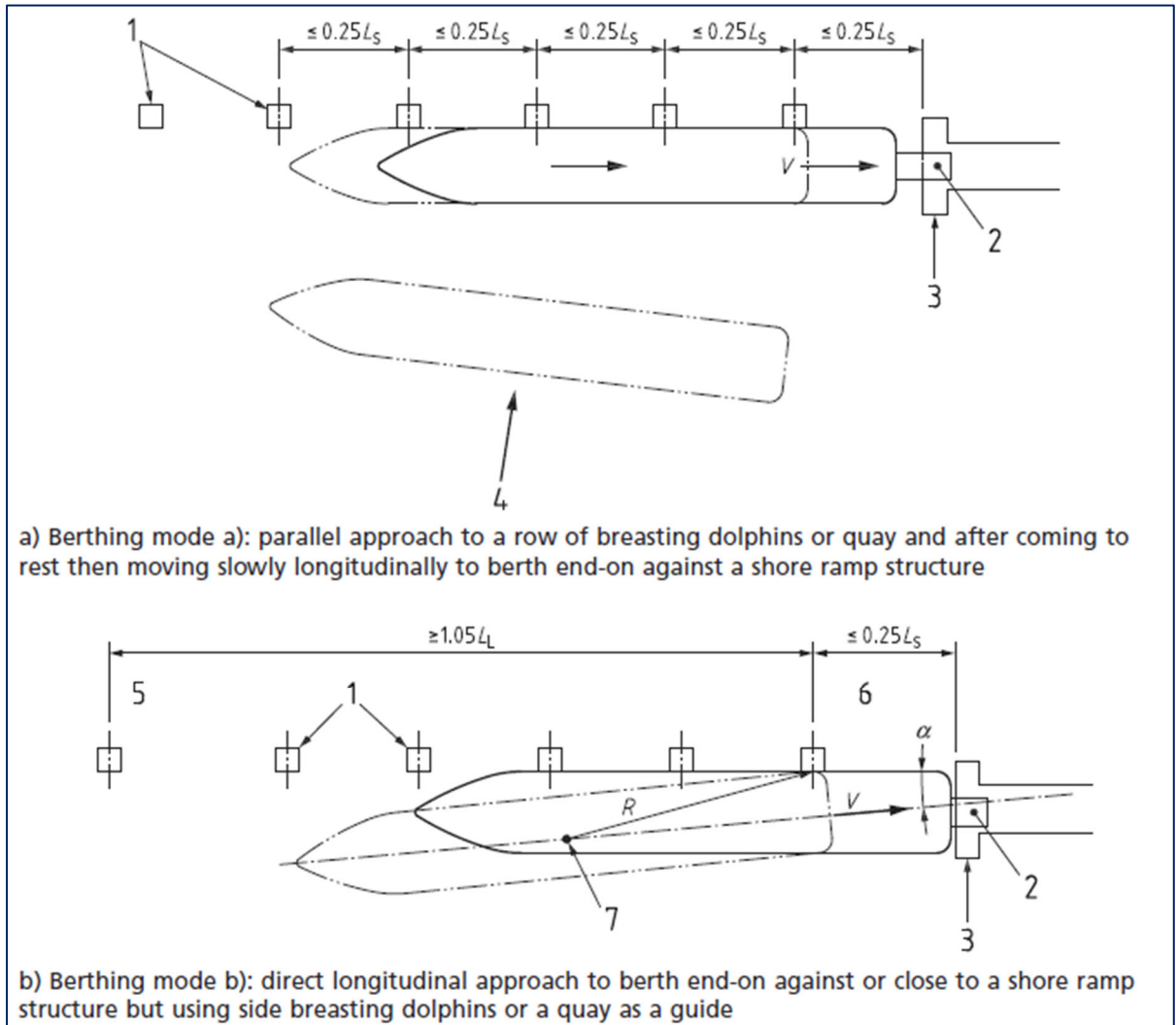

Figure 2-2: Mooring and Breast Dolphin arrangement.

2.7.4.3 Berth Geometry

Table 2-24 below presents the berth geometry parameters.

Table 2-24 – Quay geometry

Design parameter	OWSB Berth Design Value
Top of ramp landing and dolphin capping level (m Kr)	+3.00m Kr (+3.08m EV)
Min Dredge depth alongside berth (m Kr) (top of scour protection – if required)	Min -12.50m Kr (-12.42m EV)
Berthing line offset from quay face	Minimum 2m
Ro-Ro Area length	105m

2.7.4.4 Mooring Equipment

Table 2-25 below outlines the mooring equipment requirements.

Table 2-25 – Mooring equipment

Design Parameter	OWSB Berth Design Value
Bollard type	To be determined by the Contractor through a vessel berthing and mooring analysis
Bollard capacity	To be determined by the Contractor through a vessel berthing and mooring analysis

2.7.4.5 Ro-Ro Berth and Ramp Requirements

The Ro-Ro Berth and Shore Ramp shall comply with following requirements:

Shore ramp characteristics

- Minimum width: 25m
- Shore ramp height (to ensure optimal on/off loading operations):
 - minimum 1.5m above high spring tide
 - maximum 4.7m above low spring tide
- Line load bearing capacity: min. 60t/m
- Slope: the longitudinal profile of the ramp and its slope shall be agreed between the Contractor and Employer, based on local regulations and vessels' characteristics.
- Material: concrete or steel.

Ro-Ro berth characteristics

- Under Keel Clearance (UKC): min. 1m.
- Water depth: min. 8,1 m/LAT.
- Tidal range acceptable for vessel ballast system: max. 3,5 m.
- Relative movements between vessel and quay: max. ± 50 mm.
- Distance between shore ramp wall and vessel ramp touch points: min. 1m.
- Distance from vessel stern/bow to shore ramp wall: min. 1m.

2.7.4.6 Quay Equipment and Layout OWSB Ro-Ro Berth

Table 2-26 below outlines the berth equipment requirements.

Table 2-26 – Quay equipment and layout

Design Parameter	Design Value
Safety ladders and handgrips	Ladders and handgrip shall be provided on each dolphin Ladders to extend 1m below design low water level
Cat walks	Catwalks shall be designed to connect each dolphin for safe access for operations personnel to each bollard and fendering point.

2.7.4.7 Imposed Loads – OWSB Ro-Ro Operations.

The OWSB Ro-Ro Area (including quay walls) structures shall be subject to the maximum superimposed loads in the vicinity of the Berth/Area as specified in Section 2.9. The footprint of areas in the OWSB in which the various imposed loads could be located/positioned are shown on the Drawings.

These loads shall be in addition to environmental, berthing, and mooring loads.

2.7.4.8 Imposed Loads– Container Operations

To accommodate the future Container Terminal, the RoRo quay walls shall be designed to carry the superimposed loads specified for the Inbound Berth (Section 2.7.2.7), in addition to environmental, berthing and mooring loads.

2.7.5 Easterly Interface Wall

The Easterly Interface Wall will not be used as a berth for the OWSB and container operations. The design need only consider environmental loading and imposed loading behind the wall during OWSB/container operations. The Easterly Interface Wall will be classified as a temporary structure which will be obsolete when the T4 terminal is constructed.

2.7.5.1 Retaining Wall Geometry

Table 2-27 below presents the retaining wall geometry parameters.

Table 2-27 – Quay geometry

Design parameter	OWSB Berth Design Value
Wall cope level (m Kr)	+3.00m Kr (+3.08m EV)
Dredge depth alongside berth (m Kr)	Existing seabed level-no dredging required
Wall length (m)	398m

2.7.5.2 Retaining Wall Equipment and Layout

Table 2-28 below outlines the berth equipment requirements.

Table 2-28 – Quay equipment and layout

Design Parameter	Design Value
Safety ladders and handgrips	<p>Not more than 30m centres</p> <p>Ladders to extend 1m below design low water level</p> <p>Ladders are to be recessed so as not to protrude beyond the cope line and protect by vertical bollards to allow safe evacuation</p> <p>Handgrips shall be provided at deck level</p>

2.7.5.3 Imposed Loads – OWSB Operations

The OWSB Easterly Interface Wall structures shall be subject to the maximum superimposed loads in the vicinity of the wall as specified in Section 2.9. The footprint of areas in the OWSB in which the various imposed loads could be located/positioned are shown on the Drawings.

These loads shall be in addition to environmental, berthing, and mooring loads.

2.7.5.4 Imposed Loads – Container Operations

To accommodate the future Container Terminal, the Easterly Interface Wall shall be designed to carry the superimposed loads specified for the Inbound Berth (Section 2.7.3.7), in addition to environmental, berthing and mooring loads.

2.7.6 Gantry Cranes and Crane Rails

The gantry cranes and crane rails are specific to the container operations. The OWSB does not require these, and they do not have to be installed. However, the Contractor must take into consideration the crane rail loads when designing the OSWB Outbound quay structure and the future rail foundations/beams needs to be integrated into the final OSWB Outbound quay structure.

2.7.6.1 Rails

The requirements for the seaside and landside rails are provided in Table 2-29:

Table 2-29 – Quayside gantry crane rails

Design Parameter	Design Value
Rail span – centre line / centre line	35.0m
Rail type	A150 to DIN 526, grade to be determined by the Contractor to suit the defined equipment loads
Seaside rail level	To tie in with the T1 seaside rail level
Landside rail level	To tie in with the T1 seaside rail level
Rail slot width	To suit rail system
Rail slot depth	To suit rail system
Rail slot drainage	Required

Distance between the crane rail and the edge of concrete should be a maximum of 5 cm. This should allow for smooth through passing for internal movement vehicle (IMV) with full load.

Rail channels should be equipped with drainage system connected to the terminal storm water drainage network. Drainage inlets should be designed to prevent a blockage of the system.

The finished rail tolerances shall be as stated below:

- Joints +/- 0.5mm
- Lateral adjustment within rail clip \pm 8mm
- Maximum lateral adjustment following installation shall be \pm 5mm.
- After the construction, installation and final adjustment, the system should allow for +/-15 mm adjustment without cutting and welding (in both directions)
- The system should allow for height adjustment +/-20mm.
- The top of STS crane head should be in line with the top of the concrete on side with +5mm tolerance.

2.7.6.2 General Parameters, Wheel Configuration and Loads

Table 2-30 – Quayside gantry crane general parameters and loads

Design Parameter	Design Value
Equivalent crane rail load in service	Seaside and landside rail: 150t/m
Loaded length per corner	10m
Horizontal load perpendicular to rail	Seaside and landside rail: 20t/m
Horizontal load parallel to rail	Seaside and landside rail: 20t/m
Provisional buffer load	130t per rail and assumed to act at 1m above the top of the rail
Provisional anchor pin load (storm)	225t per pin

Provisional tie-down loads (storm)	80t vertical at each
Minimum buffer to-buffer spacing	1.0m
Distance between corner axes per leg/ travel wheel gauge	18m
Buffer to Buffer distance	28m
Loaded Length	10m
Wheel number per corner	10
Wheel Spacing	1000mm
Wheel diameter	710mm

The following design assumptions shall be made:

- The design shall consider the following two load cases as a minimum:
 - The maximum wheel loads at the spacing indicated above, applied by several adjacent cranes (A maximum of 10 No. STS cranes shall be considered in a section of 500 m)
 - The design shall consider the equivalent UDL loading over the loaded corner lengths of adjacent cranes.

2.7.6.3 Crane Cable Connection Pits (Turnover Pits) and other Fixtures

Table 2-31 – Quayside gantry crane cable connection pits and other fixtures

Design Parameter	Design Value
STS gantry crane cable connection pits (turnover pits)	<p>3 Nr double pits on seaward side of front rail to accommodate 2 STS cranes per pit for maximum cable travel distance of 350m. Location of pits to be designed with T1 cranes and STS turn pit in mind.</p> <p>Pump not to be provide, but the Contractor to ensure that provisions for the pits to be sealed to ensure pooling of water does not occur.</p> <p>High and low level alarms to be provided, installed and implemented to BMS system</p> <p>LV power supply for tools, pit lighting and drainage pumps</p> <p>Junction boxes must be compatible with those of the Radiolox box specification</p>
STS gantry crane storm tie down slots (pairs)	As indicatively shown on the Drawings
STS gantry crane tie down points	As indicatively shown on the Drawings
Gantry crane cable trench	<p>Offset distance between cable trench and front crane rail CL (seaside), must be aligned with T1</p> <p>5 Nr 90mm dia. cables to be accommodated in a vertical arrangement</p> <p>Proprietary belted cover to provide protection to cable slot and prevent trip hazard</p>
STS Jack Up Points (pairs per STS rail)	As indicatively shown on the Drawings

2.8 Vessel Scour Protection

It is the intention of the Employer not to utilise any physical stone/rock scour protection. Where possible, the Contractor should design for scour protection through compensation in lower pile toe depths to prevent undermining of the structure and stability is maintained.

If scour protection is deemed required, loose rock is deemed unsuitable, and the Contractor shall first submit his design for the approval of the Engineer. Scour shall be calculated considering the following based on the largest vessel to utilise the berths this shall be based on the HMM Algeciras-class container ship.

- Engine power;
- Propeller diameter;
- Number of propellers.
- Rudder arrangement.
- Bow thruster size and power;
- Depth at berth; and
- Restrictions imposed by the quay.

Scour protection shall be based on both the German and Dutch methods defined in PIANC MarCom WG 180: Guidelines for protecting Berthing Structures from Scour Caused by Ships (2015).

2.9 Surfacing / Paving

2.9.1 Definition of Imposed Loads

The imposed loads for the OWSB are defined in terms of:

- Uniformly Distributed Load (UDL)
- Maximum Ground Pressure (MGP)
- Baseline Ground Pressure (BGP)

The definition of these terms is described below:

Uniformly Distributed Load (UDL)

The UDL is calculated based on the load spread shown in Figure 2-3 below.

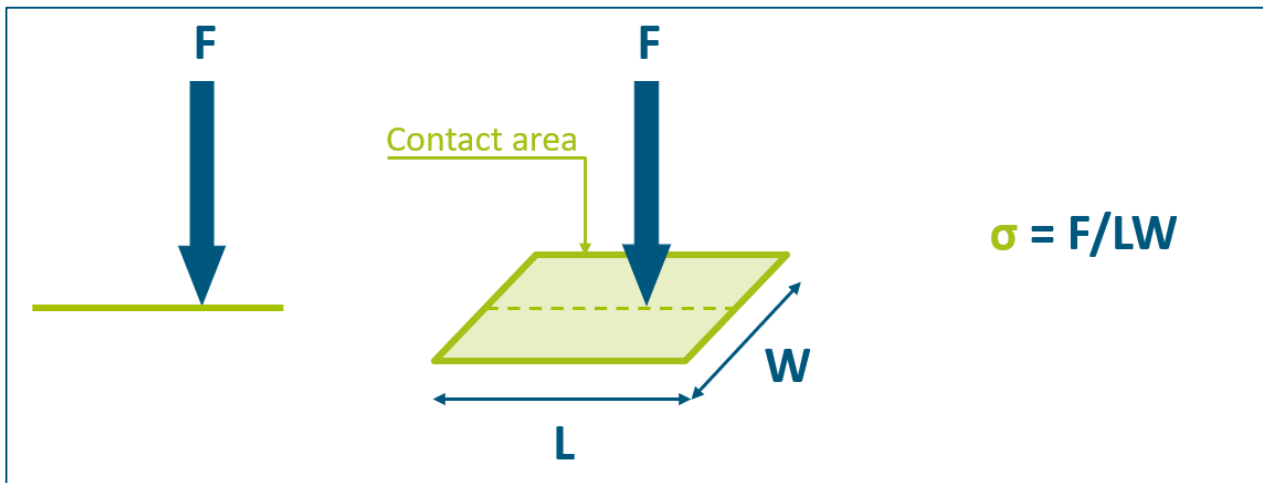

Figure 2-3 Uniformly distributed load calculation

Maximum Ground Pressure (MGP)

The MGP is calculated based on the load spread shown in Figure 2-4 below.

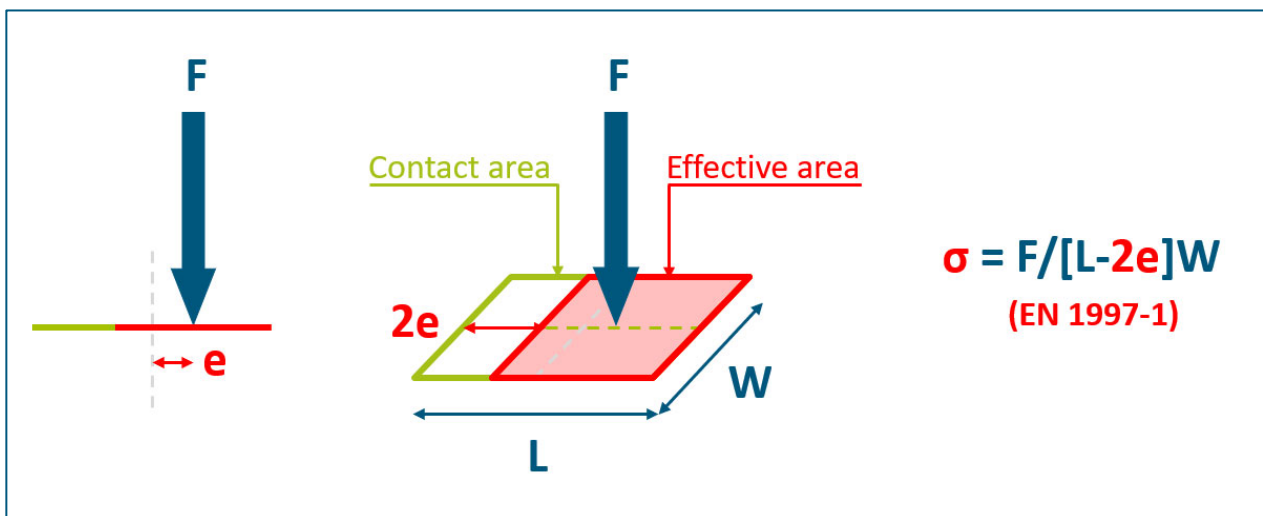

Figure 2-4 Maximum ground pressure calculation

Baseline Ground Pressure (BGP)

The BGP is calculated based on the load spread shown in Figure 2-5 below. The BGP is a result of dispersing the load in question through load spreading measures (for example, timber mats).

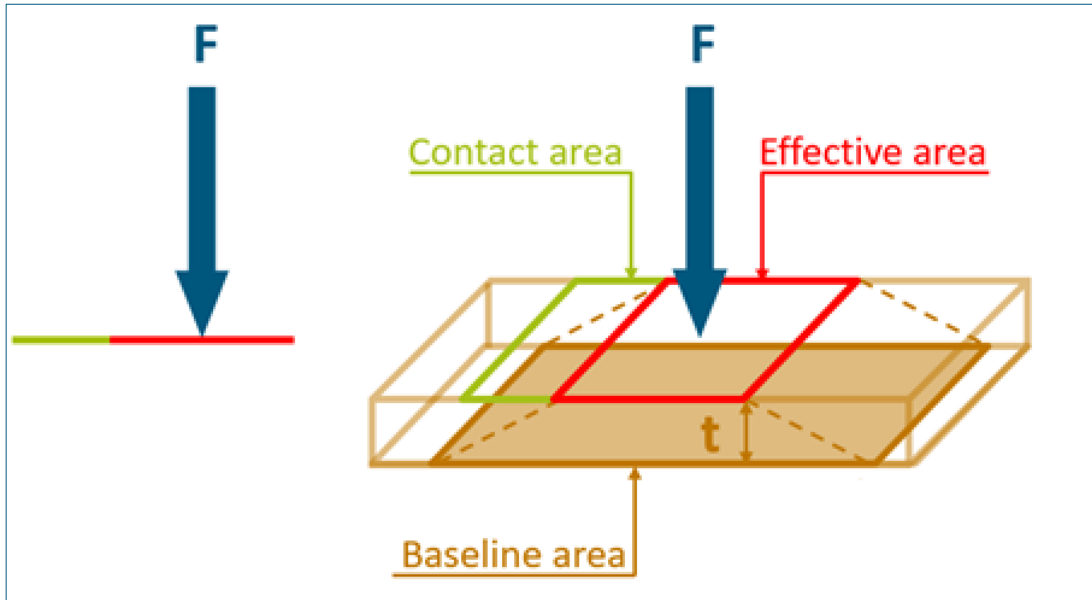

Figure 2-5 Baseline ground pressure calculation

2.9.2 Design Loads

2.9.2.1 Self-Propelled Modular Transportation vehicles

The surface/pavement design, in the relevant areas, shall take account of loading by SPMT's with a maximum 500KPa axle load as shown in Figure 2-6 below:

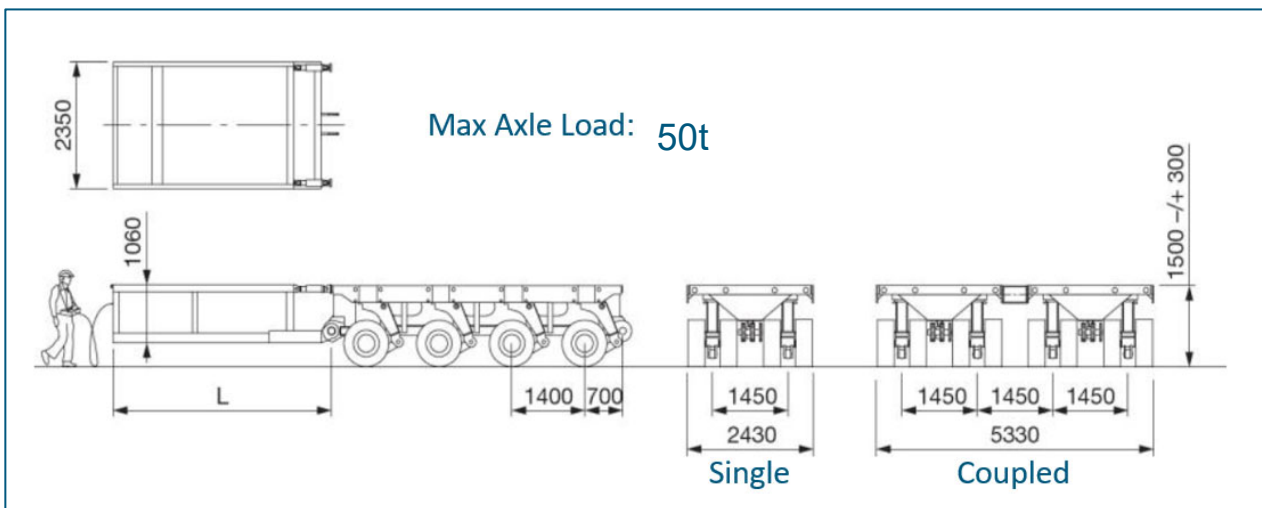

Figure 2-6 Self-propelled modular transportation vehicle (SPMT)

The design coupling/length of the SPMTs shall be determined by the Contractor based on the requirement to transport wind turbine components.

The SPMTs shall be able to travel/be positioned at any location within the applicable areas specified in Table 2-32.

2.9.2.2 Mobile Harbour Crane 1

The arrangement/loads for Mobile Harbour Crane 1 are based on the Liebherr LR 1750/2 crane, shown in Figure 2-7 and Figure 2-8 below:

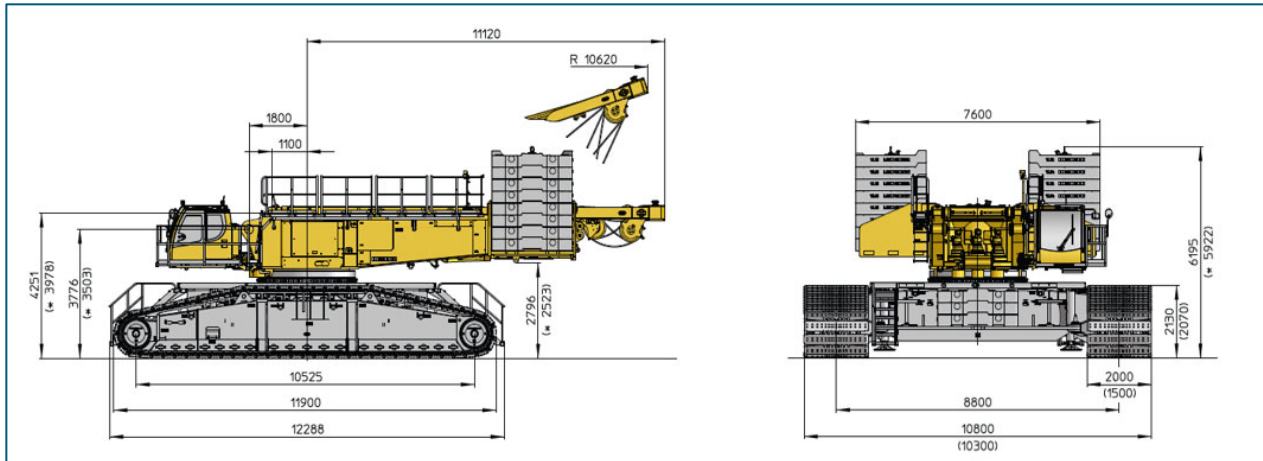

Figure 2-7 Liebherr LR 1750/2 crane arrangement

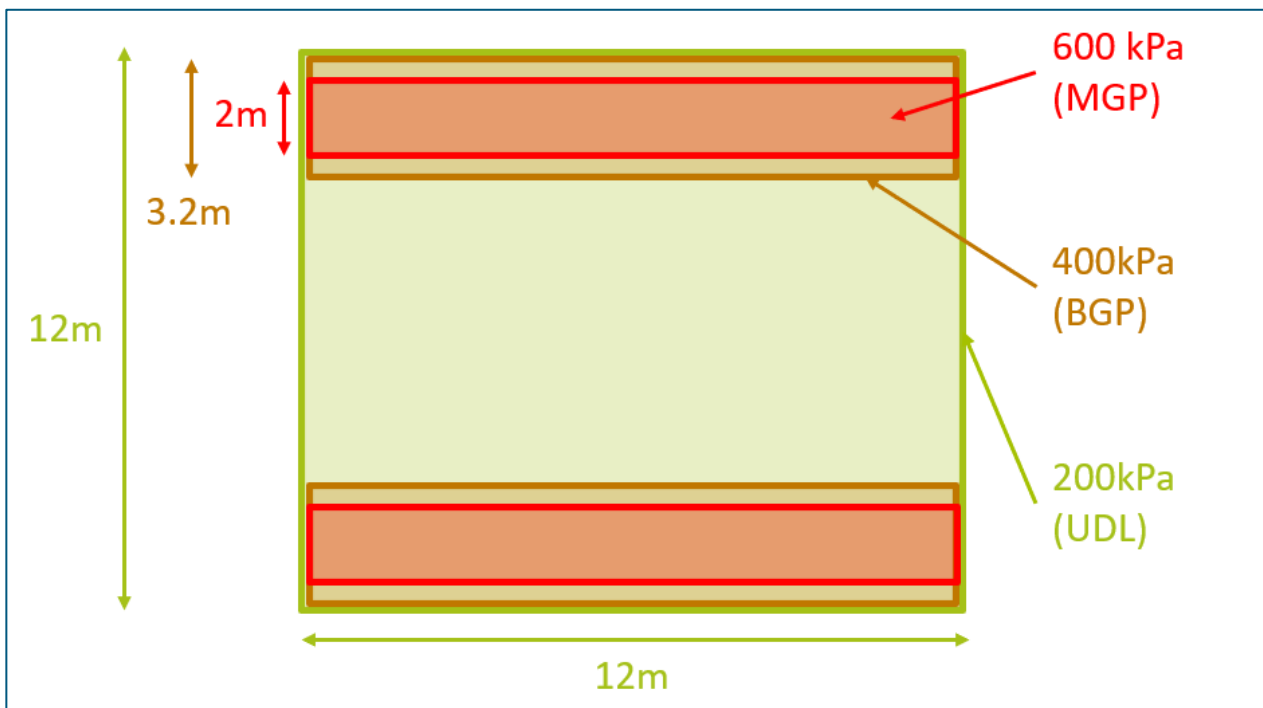

Figure 2-8 Liebherr LR 1750/2 crane load

The Mobile Harbour Cranes shall be able to travel/be positioned at any location within the applicable areas specified in Table 2-32.

The Contractor shall verify the arrangement/loading to ensure it provides the most onerous loading.

2.9.2.3 Mobile Harbour Crane 2

The arrangement/loads for Mobile Harbour Crane 2 are based on the Liebherr LR 11350 P1800 crane, shown in Figure 2-9 and Figure 2-10 below:

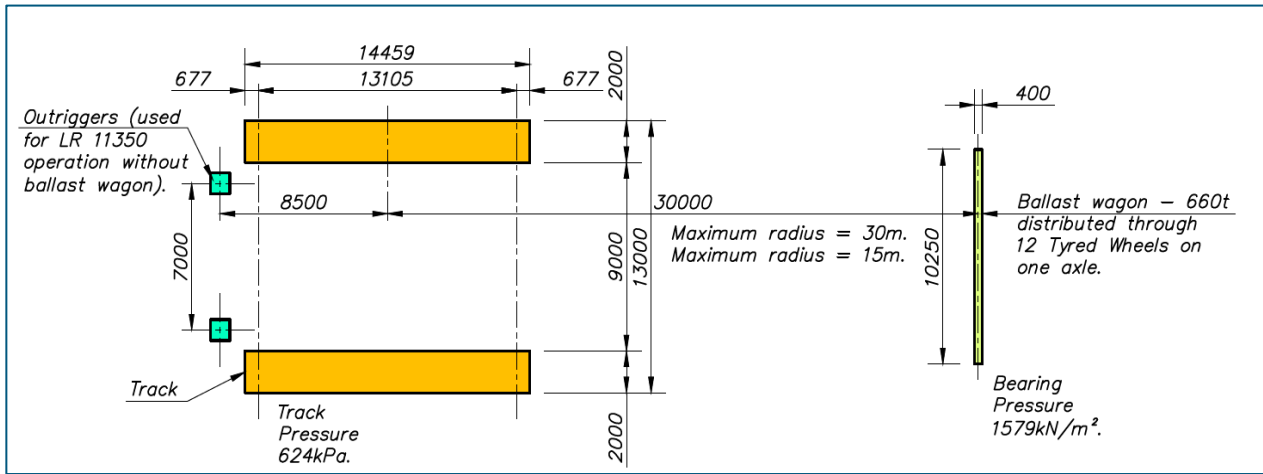

Figure 2-9 Liebherr LR 11350 P1800 crane

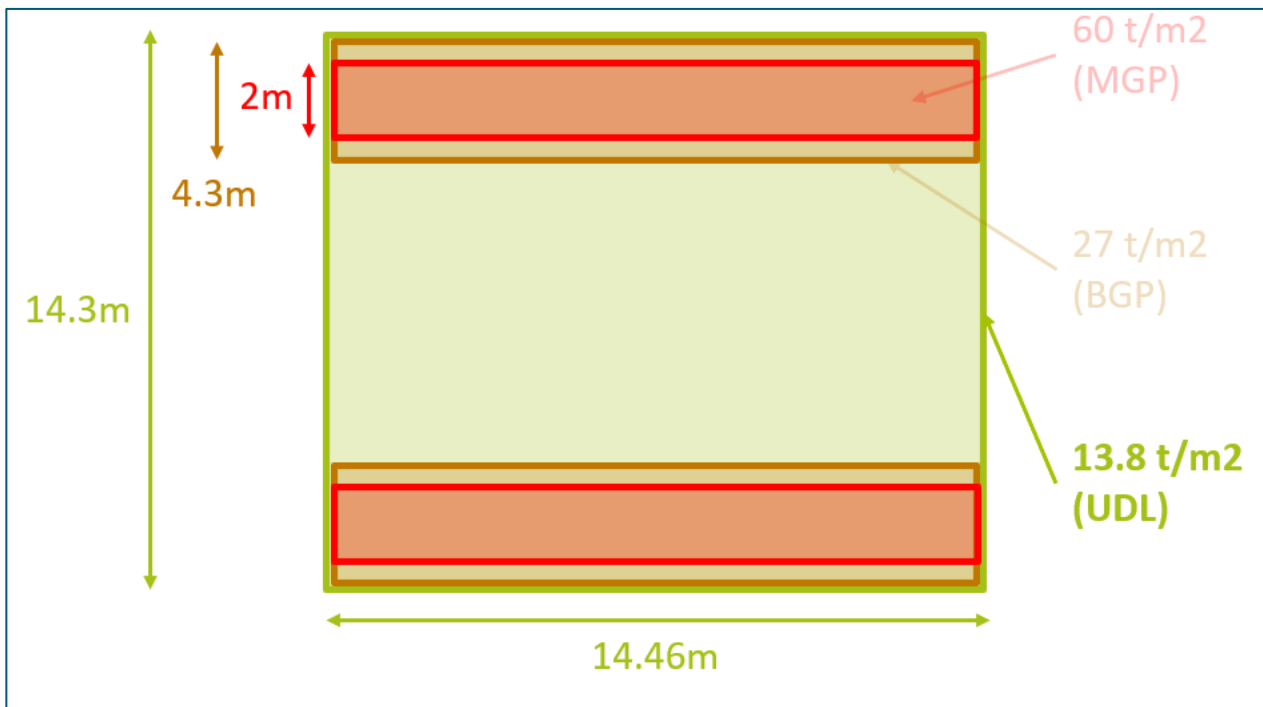

Figure 2-10 Liebherr LR 11350 P1800 pressure calculation

The Mobile Harbour Cranes shall be able to travel/be positioned at any location within the applicable areas specified in Table 2-32.

The Contractor shall verify the arrangement/loading to ensure it provides the most onerous loading.

2.9.2.4 Nacelles

The arrangement/loads for the nacelles are shown in Figure 2-11 and Figure 2-12 below.

The design pressures calculated in Figure 2-12 are based on the assumption that the nacelles will be positioned on a typical nacelle storage base as shown in Figure 2-11 with the assumed dimensions shown. The Contractor shall verify the loads for his design.



Figure 2-11 Nacelle

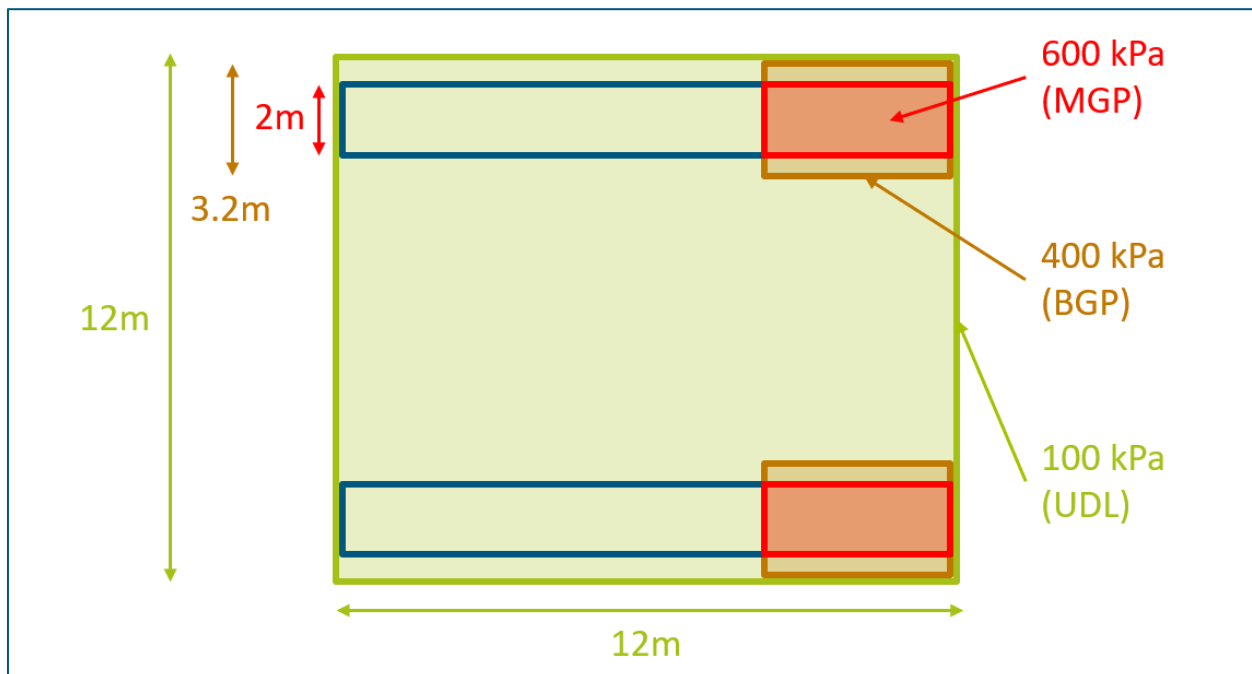

Figure 2-12 Nacelle pressure calculation

The nacelles shall be able to be positioned at any location within the applicable areas specified in Table 2-32.

Multiple nacelles can be positioned adjacent to each other.

The Contractor shall verify the arrangement/loading to ensure it provides the most onerous loading, based on the following:

- Nacelle maximum weight = 800t
- Nacelle support frame = 50t

2.9.2.5 Tower Frames

The arrangement/loads for the tower frames are shown in Figure 2-13 and Figure 2-14 below.

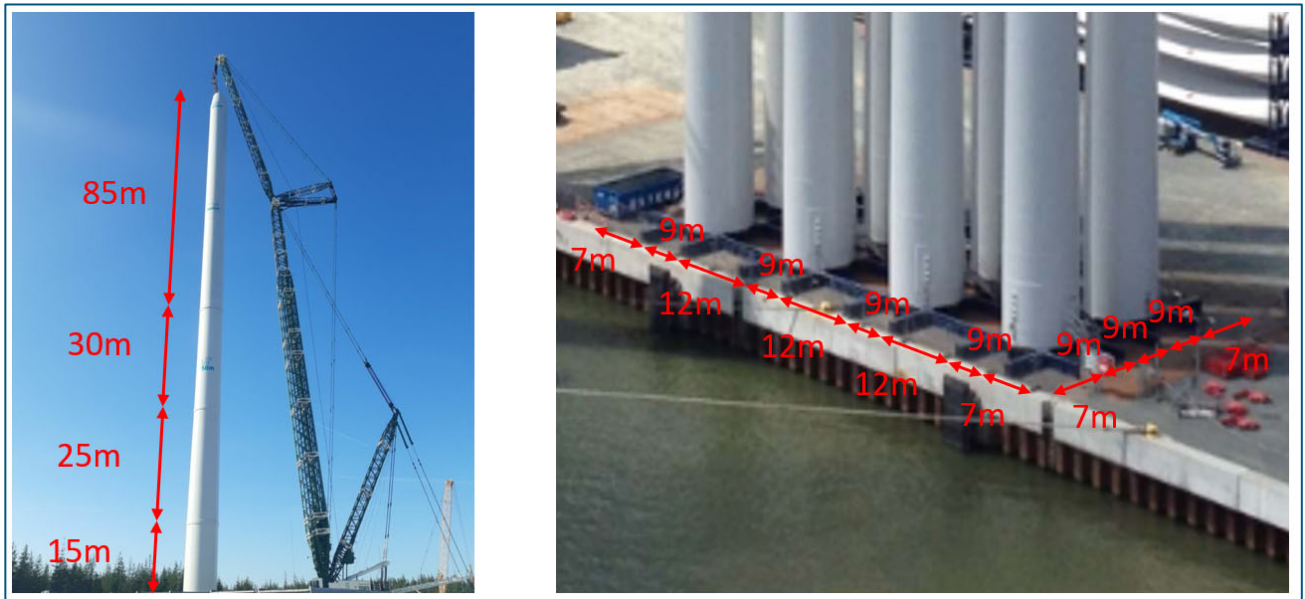

Figure 2-13 Tower frames

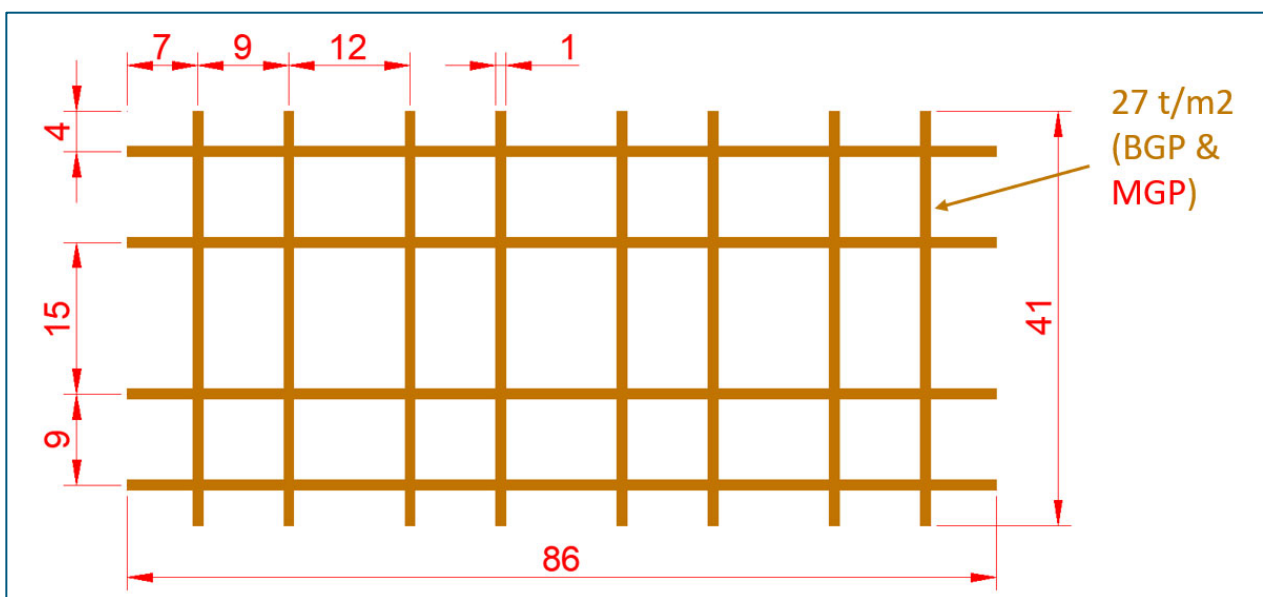

Figure 2-14 Tower frames pressure calculation

The tower frames shall be able to be positioned at any location within the applicable areas specified in Table 2-32.

The tower frames can be orientated parallel and perpendicular to the Outbound Berth. Multiple tower frames can be positioned adjacent to each other.

The Contractor shall verify the arrangement/loading to ensure it provides the most onerous loading based on the following parameters:

Load parameters - full tower assembled (unfactored)		
	Units	Value
No cans per stand:		8
Tower weight:	[t]	1100
Tower height	[m]	160
Pile diameter, base	[m]	Min 10m
Pile diameter, top	[m]	7.7

A 10-year return period basic wind speed (10 min average at 10 m above ground) shall be used for the calculation of the wind load on the towers due to gust buffeting, in line with EN 1991-1-6 and EN 1991-1-4. The design wind shall be considered to act in all directions.

2.9.2.6 General Surcharge

The following general surcharges shall be considered in the design:

- 200kPa
- 100kPa
- 20kPa

The location of these surcharges shall be as defined in Table 2-32.

2.9.2.7 Load Summary

Table 2-32 Load Summary

Area	Description	SPMTs	Mobile Harbour Crane 1	Mobile Harbour Crane 2	Nacelles	Tower Frames	200kPa Surcharge	100kPa Surcharge	20kPa Surcharge
1	Pre-Assembly Area	Yes	Yes	Yes	Yes	Yes	Yes	No	No
2	Inbound Area	Yes	Yes	No	Yes	No	Yes	No	No
3	Storage Area	Yes	No	No	Yes	No	No	Yes	No
4	Ro-Ro Area	Yes	No	No	No	No	Yes	No	No
5	Access Road	No	No	No	No	No	No	No	Yes +other see section 2.9.4
6	Crew Transfer Road	No	No	No	No	No	No	No	Yes

2.9.3 Further Requirements - Ro-Ro Area

The terminal landside area directly behind the Ro_Ro berth and where the vessel's ramp makes contact with the terminal will need to be designed as a concrete paved area and shall be subject to the loading highlighted in Table 2-32. The minimum number of equivalent axle passes from the SPMT shall be no less than 1,040 laden passes per annum and 1,040 unladen passes per annum over the design life of the paving.

2.9.4 Further Requirements – Access Road

The access road shall be design so that it is compatible with the future Container Terminal access road and shall be designed to accommodate the traffic loads presented in 2.7.1.8.

The minimum number of passes to be applied in the design of the pavement over its design life shall be as follows:

- TTUs – minimum 1,404,785 laden and unladen combined

In addition, the pavement shall be designed for occasional loading by unladen reach stackers, empty container handlers, forklift trucks, mobile cranes and a snow plough moving from one part of the yard to another. A minimum value of 2000 movements per annum shall be adopted for each type of equipment.

2.9.5 Further Requirements – Crew Transfer Route

A designated access route to the outbound vessels is needed from the terminal compound and must be segregated from the Preassembly and Storage Area. The access for crews must segregate the Preassembly Area from the access to the vessel gangway. The dedicated access walkways/ roads/ car parks are a PPE free zone and shall have an access control system in place (e.g. turnstile with card system)

The minimum requirements of the crew transfer corridor are as follows:

- Access for crew (pedestrian) minimum 1,5 m wide to allow two persons to walk side by side or to pass safely.
- Designated walkway surface must be level, suitable for foot traffic and free from obstructions.
- Access for crew with bus/car: 6 m wide
- Sufficient quayside to allow installation vessel to provide safe and secure gangway or other suitable means of access between the vessel and quayside

2.9.6 Ground Settlement

2.9.6.1 Quay Areas (Pre-Assembly Area, Inbound Area, Ro-Ro Area)

The surface of the area where the foundation of the full tower frame is located and the mobile harbour cranes working area should be levelled with a maximum slope of 0.3 deg (equal to 0.5%). Minor differential settlement during project execution is allowed but not exceeding the slope of 0.3 deg;

2.9.6.2 Storage Area

The surface of storage areas and roads should have a maximum slope of 1.5% (+/- 0.5%). A maximum differential settlement of 1.0 % during project executing is allowable.

During the storage and handling of the OWSB components on the terminal, the weight of components will induce significant load to the ground. The layout and ground bearing solutions must be prepared to fulfil the related inclination and settlements constraints, absolute and differential.

2.9.6.3 Design Method

The design method for the terminal surfacing/paving shall be in accordance with the codes of practice and standards approved by the Engineer.

Calculations shall be performed to demonstrate that the surfacing/pavement can resist environmental conditions and applied loads from the specified equipment. In particular, calculations shall be supplied to show how loads are resisted at joints including expansion joints, contraction joints and isolation joints for rigid pavements.

The movement of concrete at joints resulting from shrinkage and thermal movement shall be estimated and this shall be taken into account when specifying sealant.

Crack widths shall be assessed by calculation and it shall be shown that the Contractor's design limits cracking at the top surface of the paving to 0.3mm, maximum.

Appropriate stability analyses shall be undertaken to demonstrate the stability of all filled areas on the Terminal. The minimum factor of safety against slope failure shall be 1.5 under static loading.

The Contractor's design shall ensure, that the limiting overall settlement criteria for the reclamation and the factors of safety on overall stability shall be achieved.

The calculations submitted shall include, but not be limited to, the following:

- a) A contents sheet;
- b) Detailed written methodology setting out the design philosophy, construction programme and design assumptions;
- c) Geotechnical parameters adopted for the design together with any required supporting interpreted factual data and geological sections;
- d) Any assumptions made in developing the geotechnical design data and parameters shall be reported and justified. Copies of references used to justify the design parameters and assumptions shall be supplied with the calculations;
- e) The properties/parameters of the fill material and any ground improvement required by the design, and how the attainment of these properties shall be assessed in the field for material both above and below the water level;
- f) Information on the relevant standards and regulations
- g) What action could be taken should the monitoring indicate that the parameters required by the design will not be achieved or the requirements given in the Employer's Requirements will not be satisfied, in particular in relation to the fill material and/or the method of ground improvement.

In places where the new pavement/surfacing connect to the existing one, the transition zones should be designed in such a way as to ensure:

- smooth passage (no faults and unevenness),
- maintaining the permissible slopes of the pavement/surfacing
- adequate drainage of water, also from the existing surrounding surfaces

2.10 Surface Water Drainage

2.10.1 OWSB – Surface Water Drainage

The surface water drainage for the OWSB can be designed as an integral solution with the gravel paving/surfacing of the OWSB, whereby the surfacing is considered as permeable allowing surface water to drain directly into the gravel bed.

The drainage layer is at the pavement surface and becomes a 'gravel bed'. In these situations, the gravel is designed to accept Sub-Surface Collector Drains designed to accept 100 % of the rainfall falling directly on it plus any that is channelled into the gravel bed from surrounding impermeable/less permeable pavements.

To comply with the existing Environmental Decision the gravel surfacing medium must be 'tanked' with an impermeable geotextile membrane which will prevent the water collected in the gravel medium to enter into the sub-base and water course without first being filtered into collector pipes and an oily water interceptor.

The water collected in the gravel medium shall be channelled out of the outfalls designed in the main T5 Quay Walls via buried collector pipes. Please refer to the T5 Building permit drawings for the outfall levels.

No flooding or ponding is allowable of the surface of the terminal, collector pipes and depth of the gravel medium shall take this into consideration for saturation and permeability parameters.

Alternately, the Contractor may propose and design the surface water drainage system to utilise surface galleys and graded surfaces etc instead of a permeable system integrated with the surfacing. However it is critical that the final design ensures that no surface water run off can be discharge to the sea without first having gone through an oily water interceptor.

2.10.2 Design Rainfall Criteria

The storm water runoff shall be calculated using MicroDrainage software or similar.

Surface water run-off from impermeable surfaces shall be calculated in accordance with PN-S-02204:1997 and PN-EN 12056-2:2002 as follows:

To ensure that the drainage design is sufficiently robust to convey rainfall in extreme conditions, guaranteeing its suitability to allow operations to take place during heavy rainfall periods, rainfall data from an extreme precipitation event that took place on the 14th July 2016 in the catchment of Strzyza Creek, Gdansk shall be used. This data is presented in Intensity Density Frequency (IDF) and Cumulative Rainfall Profile (CRP) form in the charts below.

Figure 2-15 - Maximum rain intensity at predetermined time curve (2016 07 14 max. sum) and rain intensity curve from the beginning of the 14 July 2016 (2016 07 14) event together with IDF curves of rain models

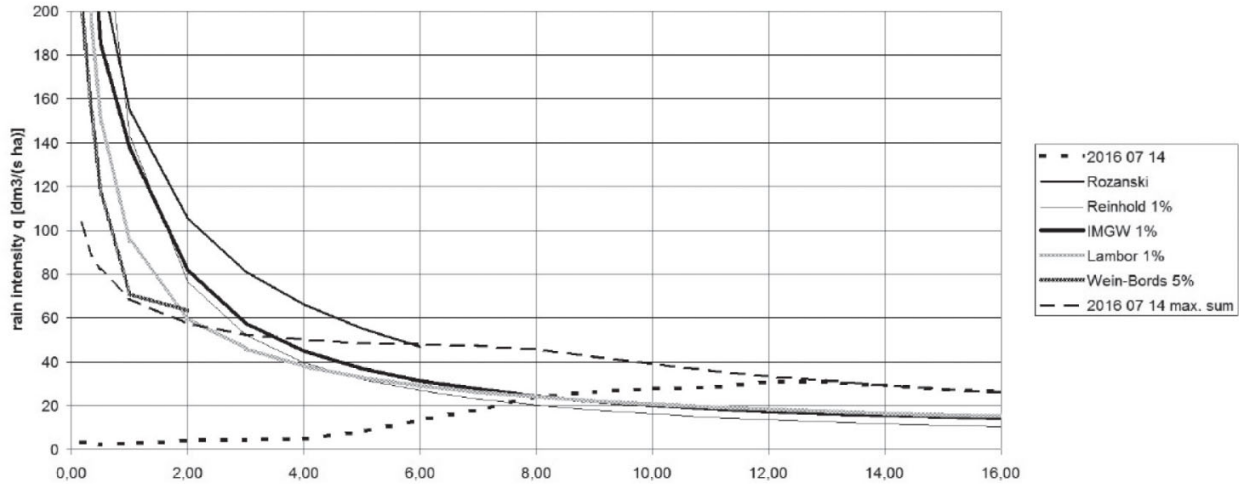
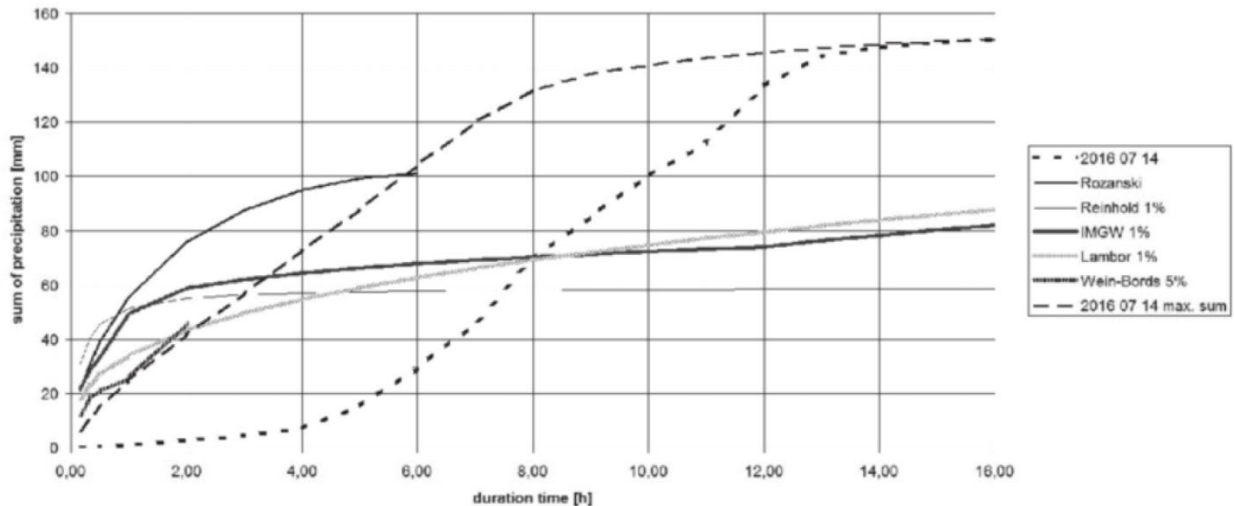

Figure 2-16 - Maximum rain sum at predetermined time curve (2016 07 14 max. sum) and rain sum curve from the beginning of the 14 of July 2016 (2016 07 14) together with DDF curves of rain models



The rainfall runoff volumes generated within T5 must be collected by suitably sized drainage networks which shall convey the volumes for unrestricted discharge into the sea by outfalls located along the quay.

All drainage networks shall be sized taking into consideration, appropriate catchment size, construction phasing of the terminal and the overall terminal layout.

Surface water shall pass through separators to intercept oils and other light liquids spilled on the terminal, quayside areas and hard standings prior to being discharged to sea.

All networks shall be sized to perform, as a maximum, under surcharge conditions when submitted to the above rainfall coinciding with surcharge to the outfall from high tide.

Under such conditions and in extreme rainfall conditions i.e. the design 1 in 5 year return intensity rainfall of $173.63 \text{ dm}^3/\text{s/ha}$, flooding in specific areas of the terminal may be allowed temporarily but within limit:

- Within the storage. Temporary ponding in extreme rainfall events is permitted providing that the water level will never reach the underside of the stored equipment and components. All water accumulated shall be dissipated and drained away within 20min of the rainfall event ending.

2.11 Foul Drainage

2.11.1 OWSB – Foul Water Drainage

Temporary foul drainage will be installed for the OWSB temporary offices. The foul water drainage will be limited to the area where the OWSB offices will be situated.

The total foul water discharge per head will need to be calculated and suitable foul water connections shall be provided and connected temporarily into the existing T1 waste-water network. The full wastewater network for the final T5 container terminal will not be constructed during the operation of the OWSB terminal operations. The discharge of proposed flows into the existing T1 network is to be controlled as not to surcharge the system. The suitable location for discharge and the maximum available capacity available must be confirmed by the Contractor with the Employer. The design will comply with these requirements.

The head count for number of workers to be situated on the T5 terminal within the offices is set to be 100 people. Should the capacity of high pressure sewerage line connected to T1 and T2 be exceeded, the Contractor must install waste water holding tanks on the site of the offices and buildings to discharge either back into the existing terminal sewerage system at the correct flow rate or emptied using waste water disposal trucks and services.

2.11.2 Design Methodology

Foul waste will be pumped from the connection point into a gravity piped system. The piped gravity system will encompass lifting stations at spaced intervals between the gravity networks to minimise the depth of the gravity systems. The last gravity network along the quay is then pumped into a suitable location in the existing drainage system serving Terminal 1, which ultimately connects into the public sewer network.

Staff facilities buildings located within the terminal will discharge into a gravity fed system.

Gravity piped sewers will be designed to achieve self-cleansing velocities of 0.75m/s and one third design flow.

The discharge of proposed flows into the existing T1 network is to be controlled as not to surcharge the system. The suitable location for discharge and the maximum available capacity available must be confirmed by the Employer. The design will comply with these requirements.

2.11.3 Minimum Cover to Pipes

In order to provide protection from external loads, the minimum cover to pipe soffit levels should be:

- a) Trafficked areas, 1.2m below finished pavement level;
- b) Non-trafficked areas, 0.9m below finished pavement level;

Should the above criteria not be achievable then, a 150mm minimum of concrete surround to the pipe must be applied.

2.11.4 Materials and Structural Form

Drains and outlets installed shall generally be constructed using low corrosive materials as follows;

- Service connections 150mm diameter uPVC;
- Pipes from 200mm to 300mm diameter uPVC, or Vitrified Clay;

Manhole covers shall be load Class F900, cast iron and bolted.

2.11.5 Manhole Diameters

Typical circular manholes sizes are listed below to suit specific pipe diameters. These should be used as guide for minimum size required when developing design.

Diameter of largest pipe in manhole (mm) Internal diameter of manhole (mm)

Less than 375 = 1200

375 - 450 = 1350

Where site specific requirements apply, manhole sizes could be developed to suit the project needs. Consideration should be given to constructability, maintenance and access.

2.12 Potable Water System

2.12.1 OWSB – Potable Water

The potable water demand at the OWSB stage is as follows:

Table 2-33 - OWSB Potable Water Demand

Network	Location	Qty.	No. Users	Function	Maximum Daily Demand (m ³ /day)
1	Outbound Berths (Terminal T5 only)	1	-	Vessel Bunkering	50
2	Offices (Terminal T5 Only)	TBC	TBC	Toilets, Washing and Cleaning	15
3	Maintenance Area	TBC	TBC	Washing and filling to plant and equipment	5
4	Warehouses	TBC	TBC	Washing and filling to plant and equipment	5
OWSB Total:					75

The total water demand for the future T5 container terminal is estimated peak 22.32m³/hr. Should the demands of the OWSB be greater than that of the T5 container terminal, a separate network for the water supply may be required and this shall be confirmed and verified by the Contractor.

Welfare facilities shall be supplied with water pressurised to a minimum of **2.–2.5 bar** at a flow rate of **6,84 m³/h** to match the future design parameters. Again, if water consumption is higher than the network in place it may not be suitable and this shall be confirmed and verified by the Contractor.

Potable water is bunkered by vessels along the ship berths from belowground service pits containing a potable water hydrant. Potable water is supplied to the bunkering points at 5 l/s (18.0 m³/h) with a minimum pressure of 12m head (1.18 bar).

Metering is required locally at the bunkering points by portable meters held and supplied by the Port Authority.

All other material and installation equipment for the potable water network shall comply with the specifications as set out for the container terminal.

It is to be noted that the need for higher daily demand or flow rates shall be communicated and agreed with ZMPG prior to completion of design and start of the construction works.

The potable water distribution network serving the existing T1, T2 and T3 container terminals shall be extended to supply potable water to the quayside vessel bunkering points and welfare facilities throughout the Terminal T5.

The new potable water system shall be supplied with potable water from the existing ring main and comprise of two dedicated distribution networks, serving the quayside vessel bunkering points and welfare facilities respectively.

The distribution network serving the quayside bunkering points shall, where possible, form an extension of the existing potable water distribution network owned by the Port Authority (Zarząd Portu Gdańsk) and be designed in accordance with the Port Authority's instructions and all applicable local regulations and standards.

The potable water distribution network serving the buildings shall be a separate network to that of the quayside vessel bunkering points.

2.12.2 Scope

The scope of work for the potable water system will include, but is not limited to, the design of the following:

- Primary connection to incoming water supply and / or connection(s) to the existing pipework,
- Circulation pump house (including pumps),
- Above ground potable water storage tank,
- New piped distribution network including;
 - Above and below ground pipework, bends, couplings, valves and fittings,
 - Service pits (bunkering),
 - Valve chambers,
 - Washout chambers,
 - Connections to buildings,
 - Coordination with other services,
- Any abandonment of the existing pipework if required.

2.12.3 Existing T1 & T2 Potable Water System

The T1 and T2 terminals are served by two dedicated potable water distribution networks supplied by an incoming 160mm PE water mains provided by the Port Authority and the operator Aqua-Port Sp. Mjr. H. Sucharskiego St. 69, 80-601 Gdansk. The T1 and T2 distribution water networks supply potable water to vessels at quayside water bunkering points and to various industrial, sanitary, administrative and storage buildings.

Both the T1 and T2 distribution networks are of a ring main formation with a circulation pump provided to maintain the water quality within the pipework along the berthing infrastructure by limiting water stagnation. There are no other pumping or storage facilities on site.

Potable water is bunkered by vessels along the container ship berths from belowground service pits containing a potable water hydrant. Potable water is supplied to the bunkering points at 5 l/s (18.0 m³/h) with a minimum pressure of 12m head (1.18 bar).

Metering is currently provided locally at the bunkering points by portable meters held and supplied by the Port Authority.

2.12.4 Potable Water Demand for Future Container Terminals

The potable water system shall be designed to supply bunkering points with water pressurised to a minimum of 12m head (1.18 bar) at a flow rate of 5 l/s (18.0 m³/h).

At the same time, it shall be possible to draw water from two water intake points for vessels.

The total capacity of the water supply system supplying water intake points for vessels at the T3 terminal and two additional terminals (T4 & T5), in the event of a possible expansion, is to be 10 l/s.

The water consumption figures for vessel bunkering at the T1 & T2 terminals for Q3 2019 to Q2 2020 are summarised in the table below:

Table 2-34 – DCT Water Consumption Figures

Date	Actual Circulation Station Meter Reading (Water of Vessels)	Total Monthly Usage (m ³)	No. Days	Average Daily Demand ⁽²⁾ (m ³ /day)
14-06-19	14,106	-	-	-
16-07-19	14,761	655	32	20.5
16-08-19	15,401	640	31	20.6
16-09-19	15,850	449	31	14.5
14-10-19	16,633	783	28	28.0
14-11-19	17,187	554	31	17.9
31-12-19	18,209	1022	47	21.7
20-01-20	18,496	287	20	14.4
14-02-20	18,941	445	25	17.8
16-03-20	19,465	524	31	16.9
15-04-20	19,758	293	30	9.8
14-05-20	19,902	144	29	5.0
15-06-20	20,247	345	32	10.8
Maximum Average Daily Demand Q3 2019 to Q2 2020 (T1 & T2 Berths) ⁽²⁾ :			28.0	
Anticipated Maximum Daily Demand (T5 berth only)			14.0	
Anticipated Maximum Daily Demand + 20% Contingency T5 only ⁽⁴⁾ :			16.8	
Anticipated Maximum Daily Demand (T3, T4 & T5 Berths) ⁽³⁾ :			41.9	
Anticipated Maximum Daily Demand + 20% Contingency ⁽⁴⁾ :			50.0	

Notes:

- 2) Total Monthly Usage (m³) / No. Days
- 3) Maximum average daily demand multiplied by 1.5 to account for 3No. vessel berths (T3, T4 & T5).
- 4) 20% contingency added to anticipated figure to allow for fluctuations in the daily demand.

The potable water demands for each respective distribution network are summarised in the table below.

Table 2-35 – Future Container Terminal Potable Water Demands

Network	Location	Qty.	No. Users	Function	Peak Hourly Demand (m ³ /hr)	Maximum Daily Demand (m ³ /day)
1	Container Berths (Terminal T5 only)	1	-	Vessel Bunkering	18	16.8
2	Buildings (Terminal T5 Only)	2	3 ⁴	Toilets, Washing and Cleaning	4.32	0.9
T5 only Total:					22.32	17.7
3	Container Berths (Terminal T3, T4 & T5 Only)	2 ⁽²⁾	-	Vessel Bunkering	36.0 ⁽²⁾	50.0 ⁽³⁾
4	Buildings (Terminal T3, T4 & T5)	6	3 ⁽⁴⁾	Toilets, Washing and Cleaning	6.84	2.7 ⁽⁵⁾
T3,T4 and T5 Total:					42,84	52.7

Assumptions:

- 1) Maximum of 2No. vessels bunkering simultaneously at any one time over three berths
- 2) Maximum daily demand based on water consumption figures provided by Baltic Hub
- 3) Four operatives per building working on a four team rotating shift pattern.
- 4) 150 litres/day/person including toilets, washing and sanitary facilities in accordance with PN-EN 805.

Based on the potable water demands in the table above, welfare facilities shall be supplied with water pressurised to a minimum of **2.–2.5 bar** at a flow rate of **6,84 m³/h**.

The potable water distribution networks and pump facilities will serve as a standalone system and not be connected to the fire water distribution network, other than for filling of the fire water storage tank.

It is to be noted that the design flow rate for the potable water supply is critical. Currently it is set at circa 18m³/hr. In order to increase this flow rate, the existing infrastructure in T1 will need to be upgraded.

2.12.5 Above Ground Storage Tanks

The Contractor shall assess whether the current designed potable water network is sufficient to satisfy the OSWB T5 water demand based on the information provided in terms of flow rate and capacity. If not, aboveground potable water storage tank(s) shall be installed, within the compound area, to ensure sufficient water is available to supply the T5 distribution network serving the quayside vessel bunkering points. For more information please refer to Employer's Requirements Section 4- Landside Utilities and Services PC1063-RHD-T5-ZZ-RP-PM-0004 for more information.

2.12.6 Circulation Pumps

Circulation pumps will be required to maintain water quality and prevent bacteriological growth, such as legionella, forming within the distribution network. Please refer to Employer's Requirements Section 4- Landside Utilities and Services PC1063-RHD-T5-ZZ-RP-PM-0004 for more information.

2.12.7 Distribution Network

The potable water distribution network shall be a combination of both direct and ring mains with branched off-take connections that meets the applicable water pressure and capacity requirements. Please refer to Employer's Requirements Section 4- Landside Utilities and Services PC1063-RHD-T5-ZZ-RP-PM-0004 for more information.

2.12.8 Incoming Potable Water Mains Supply

Potable water shall be supplied from the site's incoming mains provided by the Port Authority, via the existing T1 ring main distribution network. The pressure in the Ports water network ranges from 3.5 to 6.0 bar.

A flow meter shall be installed within a belowground chamber at the connection of the aboveground potable water storage tank to the T1 distribution network. Isolation gate valves shall be installed on either side of the water meter with a double check valve arrangement to prevent backflow and contamination of the incoming mains. A bypass arrangement shall be provided with isolation gate valves.

Potable water supplied to the site is assumed to be of high-quality drinking water and shall have physical, chemical and biological properties in accordance with the Journal of Laws Dziennik Ustaw No. 203 Item 1718.

2.12.9 Valve Chambers

Strategically located isolation valves shall be provided to accommodate the requirements in Employer's Requirements Section 4- Landside Utilities and Services PC1063-RHD-T5-ZZ-RP-PM-0004.

2.12.10 Bunkering Points

Below ground wet type hydrants will be installed along the new berthing infrastructure of the T5 terminal for vessel bunkering. The potable water hydrants will be installed within a below ground chamber and come complete with an isolation valve, water meter and drain line discharging into a sump.

The maximum spacing between bunkering points shall be **100m** as per Port Authority requirements.

2.12.11 Washout Chambers

Washout chambers shall be provided for flushing and draining the distribution network during construction and the subsequent testing, commissioning and operation of the system. Please refer to Employer's Requirements Section 4- Landside Utilities and Services PC1063-RHD-T5-ZZ-RP-PM-0004 for more information.

2.13 Fire Water System

2.13.1 OWSB – Fire Fighting Requirements

Water for firefighting purposes is stored in steel tanks above ground on Terminal T3 and is design to serve the Future T5 and T4 expansion plots. Water in the tanks will be replenished with drinking water from the port water supply system. The port fire-fighting system will provide water for external hydrants.

A pumping station is located next to the tanks to provide the required pressure to the external hydrants. The pumps will be powered by electric motors. One of the pumps will be a reserve pump with parameters not lower than the parameters of the largest pump installed. The pumps will be equipped with a measuring system consisting of a pressure gauge, flow meter and control valve allowing periodic inspection of operating parameters.

The current fire water system design at T3 is as follows:

- Capacity of installation providing water for external fire extinguishing = 60dm³/s,
- Tanks dimensioned for a fire duration of 4 hours,
- Time of filling the tanks will be no more than 48h for 50% capacity,
- The required minimum capacity of the water supply pipeline to the tanks will be 2.5dm³/s
- In the terminal area there will be DN100 underground hydrants
- The nominal output of hydrants at the nominal pressure of 0.2MPa measured at the hydrant valve during water intake will not be less than 15 dm³/s, with four simultaneously operating hydrants (4 x 15dm³/s = 60 dm³/s)

A permanent fire water network is required for the T5 OWSB and is to source all fire water from the existing T3 fire water tanks and fire water network.

The fire water network shall be design in accordance with NFPA 307 which is deemed best practice for the maritime industry and considered the most applicable industry standard for a marine terminal environment. However, the local Polish Fire Fighting Regulation and the approval of the Fire Safety Expert will still need to be complied with especially for more onerous requirements which are over and above the NFPA guidelines.

A series of scenarios will be developed to simulate internal and external fires throughout the terminal. The external firefighting system shall be designed based on the single largest fire incident. Fire water is to be supplied at the required pressure and flow rate to provide the first respondent team and fire brigade access to a suitable supply of water to combat the fires.

The main fire scenarios considered comprise of:

- Operation of the internal fire protection systems (warehouse, offices etc)
- Operation of the yard fire hydrants to fight a storage yard fire.

The supply of fire water to vessels is not considered as the vessels will be active (i.e., engines running and onboard power systems available) and hence can rely on their onboard firefighting systems.

The fire-fighting distribution network design would therefore follow that of the container terminal design requirements whereby the firefighting distribution network shall be of ring main formation with branched hydrant connections that meets the applicable water pressure and capacity requirements. The distribution network shall use high-density polyethylene (HDPE pipe) with butt fusion connections and be suitably rated to withstand the working and associated test pressures. Where possible, the final solution should be designed to be as compatible with the final container terminal layout as possible.

Water supply system will be executed as a perimeter system. The perimeter network shall be powered at two points at a distance of not less than one quarter of the perimeter of the network. This condition will be met, because around each component square a hydrant loop will be created, which will have a two-sided power supply at two points distant from each other min. 1 / 4 loop circuit. Underground hydrants will be installed on the fire water supply system.

The current firefighting network is designed to maintain a minimum residual pressure of **6.9 bar** at the most hydraulically remote hydrant in accordance with NFPA 14, while operating at a flow rate of **113.5 m³/hr** (500 gpm) as per NFPA 24 (2 x 2.5" outlets at 250 gpm each).

Based on the most critical fire scenario, in which the firefighting system is required to supply fire water to two external yard fire hydrants simultaneously, the maximum resultant flow required is **227 m³/hr** (1,000 gpm) for a minimum of **4 hours** as per NFPA 307.

This provides not only the quantity of water for extinguishing the fire, but also sufficient water for cooling during and after the fire event.

The fire water distribution network and pump facilities will serve as a standalone system and not be connected to the potable water network, other than for filling of the storage tanks.

However, the Contractor shall consider the specific fire scenarios likely to be encountered for the T5 OWSB and assess whether the current fire water network system to be connected to will be sufficient. If the system is deemed insufficient, the Contractor shall make the necessary design and local T5 fire water network improvements to provide the desired firefighting water network pressures and capacities.

2.13.2 Fire Water Pump Facility

Please refer to Employer's Requirements Section 4- Landside Utilities and Services PC1063-RHD-T5-ZZ-RP-PM-0004 for more information on firewater pumps.

2.13.3 Existing Above Ground Storage Tanks

Firewater is stored in two above ground storage tanks in T3 designed in accordance with NFPA 22 to ensure the availability of the water during maintenance and repair. Please refer to Employer's Requirements Section 4- Landside Utilities and Services PC1063-RHD-T5-ZZ-RP-PM-0004 for more information.

2.13.4 Below Ground Hydrants

Below ground wet type fire hydrants shall be installed throughout the yard to serve the new berthing and container yard infrastructure of terminal T5. Please refer to Employer's Requirements Section 4- Landside Utilities and Services PC1063-RHD-T5-ZZ-RP-PM-0004 for more information.

2.13.5 Valve Chambers

Isolation valves shall be located on each connection and crossings of the net and shall be in accordance with Employer's Requirements Section 4- Landside Utilities and Services PC1063-RHD-T5-ZZ-RP-PM-0004.

2.13.6 Distribution Network

The firefighting distribution network shall be of ring main formation with branched hydrant connections that meets the applicable water pressure and capacity requirements. Please refer to Employer's Requirements Section 4- Landside Utilities and Services PC1063-RHD-T5-ZZ-RP-PM-0004 for more information.

2.14 Electrical

2.14.1 OWSB – Electrical Requirements

2.14.2 Power Supply

The scope of the electrical works includes design of the power distribution system required for the new T5 OWSB terminal. The electrical works include supply, installation, testing and commissioning of the LV electrical distribution network for T5 OWSB terminal.

Adequate power supply for preassembly work, turbine preservation, lighting, containers, office, warehouse facilities, etc. shall be provided.

The main electrical demand requirements for the OWSB are as follows:

Table 2-36: LV Electrical requirements for the OWSB

Terminal Area	Electrical Consumer	Power Demand Required Supply: 3Phase + N+ PE	Diversified Load
Berth Area (1x8 tower pack)	Tower packs, SST charging, nacelle loadout, heavy bolt stand	278 kVA	203 KVA
Berth Area (1x6 tower pack)	Tower packs, SST charging, nacelle loadout, heavy bolt stand	208 kVA	152 kVA
Berth Area (1 x 12 tower pack)	Tower packs, SST charging, nacelle loadout, heavy bolt stand	416 kVA	304 kVA
Storage Area	HSBM Installation, 26 Nacelles, ERT	795 kVA	605 kVA
Office	1 x office	300 kVA	210 KVA
Warehouse	1 x warehouse	95 kVA	47 KVA
Platform Hall	1 x Platform Hall	188 kVA	105 KVA
All terminal	Lights on Site	124 kVA	15 KVA
		TOTAL LV POWER	1641 KVA

The total estimated power demand as per the information above is deemed to be less than that of the final T5 container terminal. The power distribution network design proposed will have a main substation on Terminal T3 with a series of modular substations located around the T3, T4 & T5 terminals which shall then in turn supply the local LV loads required for the operation of the electrical equipment during the container terminal stage. The modular substation for the OWSB will be house in a different location to the final T5 container terminal so this will not be considered compatible. The OWSB substation shall be within the office or marshalling yard compound as indicatively shown on the drawings.

Locations with 3 phase connection points are to be located in accordance with the agreed final layout of the site with the Engineer. The indicative power outlet points for the OWSB terminal are indicatively shown on the drawings.

UPS and backup power will be required.

The power distribution system shall comply with the following criteria;

- Engagement with the port authorities shall be required during concept design stage.
- The electrical distribution system shall employ a 100% redundancy for the network,
- From the main T3 substation smaller modular substation shall be installed around Terminal T5 for local power requirements

Only the civil infrastructure was allowed for T5 cold ironing facilities shown on the drawings. Power capacity has not been allowed for to support cold ironing. It is to be noted that in case cold ironing is required as part of the OWSB operations, it shall be discussed and agreed separately with ZMPG.

It is proposed that the OWSB shall be set up independently by the use of modular containerised substations with bespoke LV transformers and switch gears tailored to the needs of the offshore wind terminal.

2.14.3 OWSB Lighting

Fixed high mast lights shall be provided on site to illuminate the terminal in accordance with Table 2-38. The Contractor shall design the layout and lighting in accordance with the Employer's Requirements and to simulate all LUX levels on the terminal to prove that the parameters for each terminal areas as shown in the table below are achieved. An indicative lighting layout of fixed high mast lights is shown on the layout drawing PC1063-RHD-T5-OW-DR-LI-5000 which the Contractor must verify and design for himself to ensure the Employer's Requirements are met. All high mast lights must be designed to be easily removed from the connection of the foundation without the need to break out any foundation or fixed structural members.

The minimum lighting levels for the terminal is shown below:

Table 2-37: OWSB Lighting Levels

Location	Lighting Level			
	Average Horizontal Luminance	Uniformity	Upper limit of Glare	Minor Colour Rendering Indices
	Em	U_0 (E min/E m)	GR _L	Ra
Parking Areas	10 lux	0.4	50	20
Storage and roads	20 lux	0.4	50	20
Ro-Ro Area, Quay Side and Preassembly Area, Cargo Handling	50 lux	0.4	50	20

All lighting design must be carried out in consultation with an expert ornithologist. The impact of the lighting and high mast light structures collision risks should be reviewed and approved by the ornithologists.

2.14.4 Electrical Distribution System

The distribution network design philosophy proposed will have a main substation on the T3 Terminal designed with spare ways in distribution panel to connect power supply to T5, then a series of modular substations located around T5, which shall then in turn supply local LV loads required for the operation of the electrical equipment.

The modular substations shall be supplied from the main substation via ring circuits. This approach has the following benefits over supplying the terminal from the main substation:

- Reduce overcrowding in the cable ways in and around the main substation

- Reduce the long cable runs
- Reduce overall cable sizes
- Improve electrical redundancy within the terminal
- Better for future expansion by reducing the supplies from the main substation
- Reduce the electrical equipment required

The electrical distribution network shall provide power throughout the facility and shall include all associated civil infrastructure works including cable duct banks, pull pits, foundations and mounting structures to the facility / equipment for the power distribution networks

The distribution system shall comply with the following criteria:

Engagement with the port authorities shall be required during design stage.

The electrical system shall be in accordance with below table:

Table 2-38: Electrical Distribution Parameters

Item	Description	System Parameters	Earthing System
1	LV Power Distribution System	230/400V AC – 3 phases – 4 wire – 50Hz 3P+N+PE	Solidly Earthed

2.15 Fuel Bunkering System

A fuel bunkering system is required to provide the OWSB facility for refuelling vessels along the Outbound berth. The system shall facilitate ship-to-ship transfer of fuel via an underground pipeline running along the length of the quay with one offloading connection pit and two loading connection pits as shown on the Layout Drawings.

2.15.1 Design Life

Following T5's conversion into a container terminal, the fuel bunkering system will become redundant and all equipment within the bunkering pits removed. All pipework, valves, fittings, electro-mechanical machinery and power supplies shall therefore achieve a minimum design life of 10 years under all applicable loading, environmental and installation conditions. Any chambers, access covers, etc. which are retained shall achieve a minimum design life of 50 years.

2.15.2 Products to be Handled

The following grade of fuel will be bunkered at the OWSB facility:

- Product: Marine Gas Oil (MGO)
- Density: 850 kg/m³
- Flash Point: >55°C
- EI Petroleum Class: III (1)
- Gas Group: IIA
- Temperature Class: T3
- EI Fluid Category: C

2.15.3 Fuel Bunkering Demand

The fuel bunkering system shall be designed to enable two outbound vessels to bunker simultaneously. Each bunkering point should enable ship loading at a minimum flow rate of 100 m³/hour each (i.e. a total

accumulated system loading capacity of 200 m³/hour). Actual flow rate will be dictated by the pumping capacity of the fuel supply barge and shall be verified by the Contractor during their detailed design.

2.15.4 Design Pressure

The Contractor shall design and validate the fuel bunkering system to supply a minimum pressure of 2 barg at the loading connection pits to enable the fuel to overcome any head and friction losses when transferring fuel onboard the vessels.

2.15.5 Design Vessels

2.15.5.1 Fuel Supply Barge

A fuel supply barge for the OWSB has not yet been sourced, however the following parameters shall be used as a basis for the fuel bunkering system design:

- Length: 88.31 meters.
- Breadth: 13.5 meters.
- Draught: 5.6 meters.
- DWT: 3,550
- Delivery Flow Rate: 200-450 m³/hour
- Delivery Pressure: Max. 4 barg

2.15.5.2 Bunkering Vessels

For details of the design vessels refer to Table 2-8.

2.16 OWSB – Buildings

All buildings required in terms of welfare office and warehousing will be provided by the operator in the form of temporary cabins or containerised structures.

No permanent buildings will be constructed for the OWSB and is currently outside the scope of the design

However, the following is required for the terminal and the Contractor will ensure space and infrastructure is provided for the following requirements.

- All temporary buildings will be supplied with adequate water and power supply and connected to a sewage system
- Adequate car parking in the area adjacent to the site offices shall be provided. Minimum of 50 cars and 25 car parking spaces for visitors
- Easy access and space for allowing trucks with 40ft container to manoeuvre shall be provided. This implying for a free full-size turn area of at least 15 meter turning radius
- Space for Operators temporary site offices and welfare facilities
- Internet fibre connection to office space or equivalent with a minimum band width of 100Mbit/s

2.16.1 Site security and fencing requirements.

The terminal and staff facility areas shall be fenced in accordance with ISPS regulation to avoid unauthorized access to the onshore facilities.

A fence system must be established around the pre-assembly site (2m high).

Fence Element	Design Requirement
Height	Min. 2.0m to top mesh edge.
Spacing	Maximum width between fence posts shall be 3m

Mesh size	The maximum mesh gap size shall be either 50x50 mm or 25x100 mm, with the vertical side being longer. Wire diameter 3.5 mm
Weather protection	All elements shall be paint coated
Foundation	The foundation shall be capable of withstanding 1 in 25-year storm.
Gate	Gates shall be as per the layout drawings. Gates shall open in both directions.

2.16.2 CCTV Surveillance

Surveillance to be provided using CCTV cameras mounted on minimum 14m high masts and to be located in areas round the terminal to be agreed with the Operator and Employer.