

QUAY WALL DESIGN SHOWN MUST BE VERIFIED BY THE CONTRACTOR AND IS FOR INFORMATION ONLY.

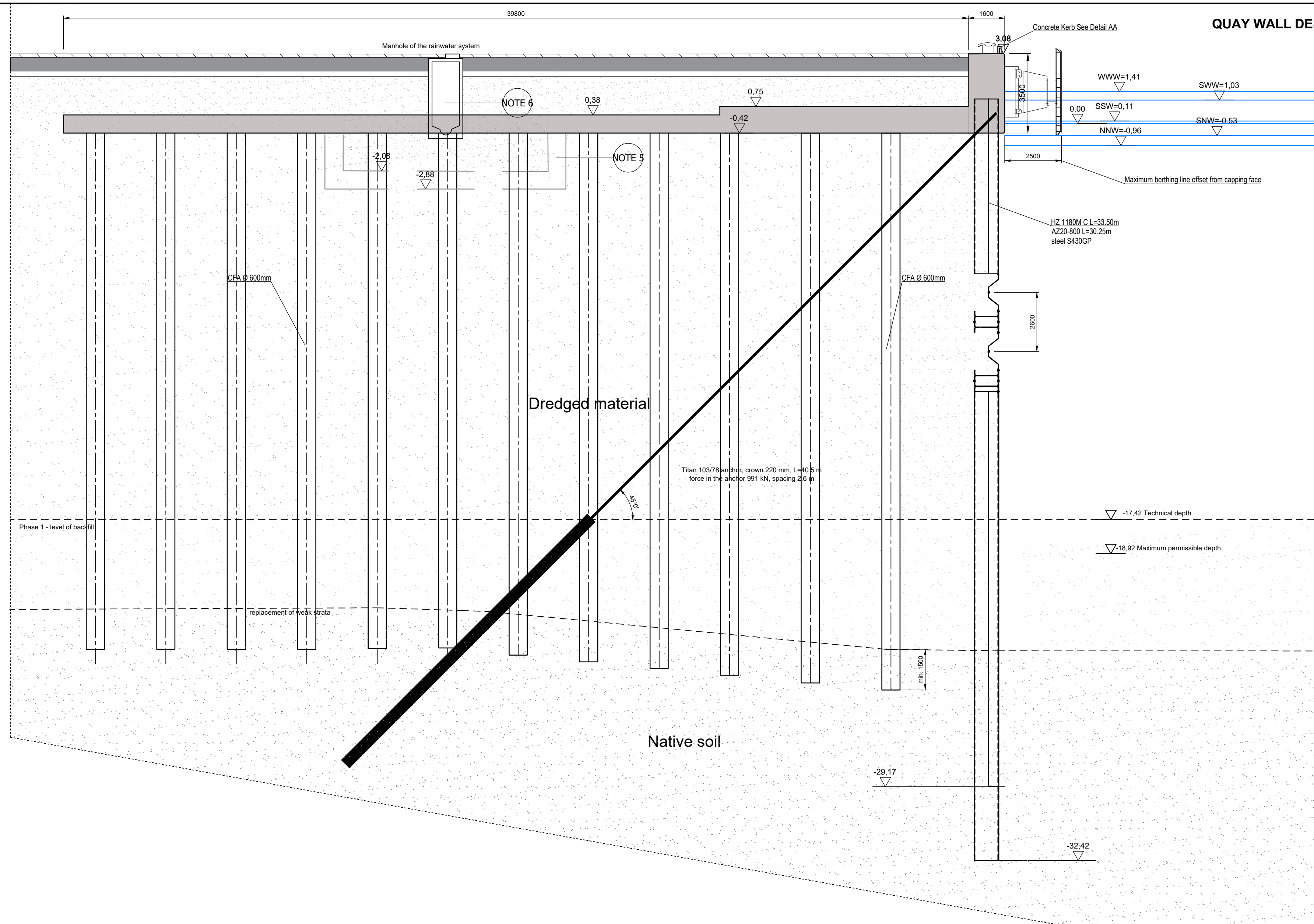

Please see Note 5 and 6 for description for soil descriptions shown

Borehole B-C-T5-30

Water	
17.81	Bs
19.21	IIIb
21.31	IIIc
21.31	Ib
23.21	IIIb
24.01	IIIc
24.81	Ic
25.21	IIIc
26.71	Ila
27.91	IIb
28.81	IIId

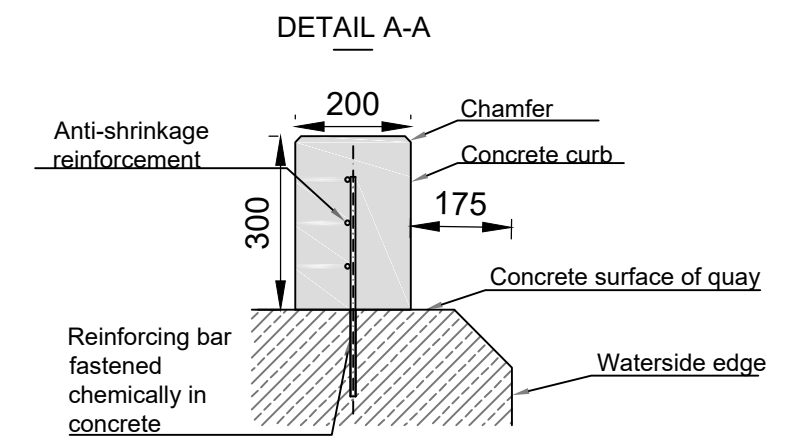

- Notes:
- All levels shown are in accordance with the EVF2007 datum (Elevations in Kr86bis + 0,08m = Elevation in EVRF2007)
 - Dimensions are in millimeters unless otherwise stated.
 - Profile and Levels of relieving platform to suit the Contractors Design of services.
 - Drainage manholes to suit the Contractor's drainage design. However, all outfall numbers, locations and invert levels must comply with the building permit design. See Building Permit and Water law permit documents.
 - Soil descriptions and parameters for the indicative soil layers shown are fully described in the Geotechnical Opinion Report- OG-74-2022 and the Documentation of Subsoil Investigations -DBPG-74-2022, both of which are included as part of the Disclosed Data.
 - The soil profiles shown are indicative only and the Contractor shall verify all soil and ground conditions to determine his own geotechnical design parameters using either the provided information and or alternative data.

NOT FOR CONSTRUCTION

TENDER

Revision	Date	Description	Drawn	Checked	Approved
P04	05/12/23	Tender Issue	ADT	AT	CSJ
P03	21/11/23	Tender Issue	ADT	AT	CSJ
P02	31/10/23	Tender Issue	ADT	AT	CSJ
P01	29/09/23	Draft tender issue	ADT	AT	CSJ
P00	11/08/23	Draft for comment	ADT	AT	CSJ

Client: ISTRANA / Baltic Hub Container Terminal Sp. z o.o.

Baltic Hub ISTRANA/ Baltic Hub Container Terminal Sp. z o.o.
ul. Kontenerowa 7, 80-601 Gdańsk

Project: **BALTIC HUB T5 OFFSHORE WIND TERMINAL PROJECT**

Drawing Title: **INBOUND QUAY AND RO-RO AREA SECTION**

Designing company:	HaskoningDHV Polska Sp. z o.o. ul. Dzielna 60 01-029 Warszawa	Drawn:	ADT	Checked:	AT	Approved:	AT
Date:	11/08/23	Scale:	1:100				
Drawing number:	PC1063-RHD-T5-OW-DR-CM-3002	SUITABILITY:	S4	REVISION:	P04		