

DOLPHIN DESIGN SHOWN MUST BE VERIFIED BY THE CONTRACTOR AND IS FOR INFORMATION ONLY.

- Notes:
- All levels shown are in accordance with the EVF2007 datum (Elevations in Kr86bis + 0,08m = Elevation in EVRF2007)
 - Dimensions are in millimeters unless otherwise stated.

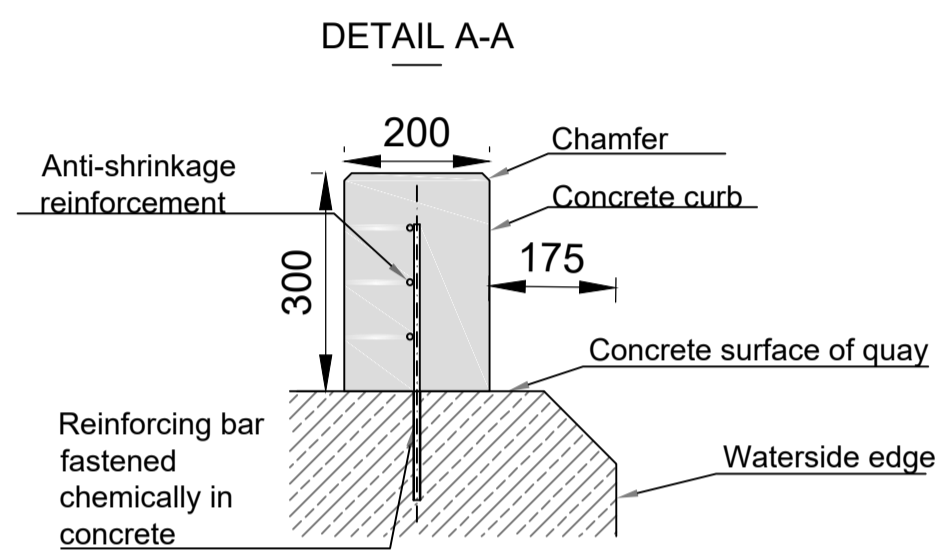
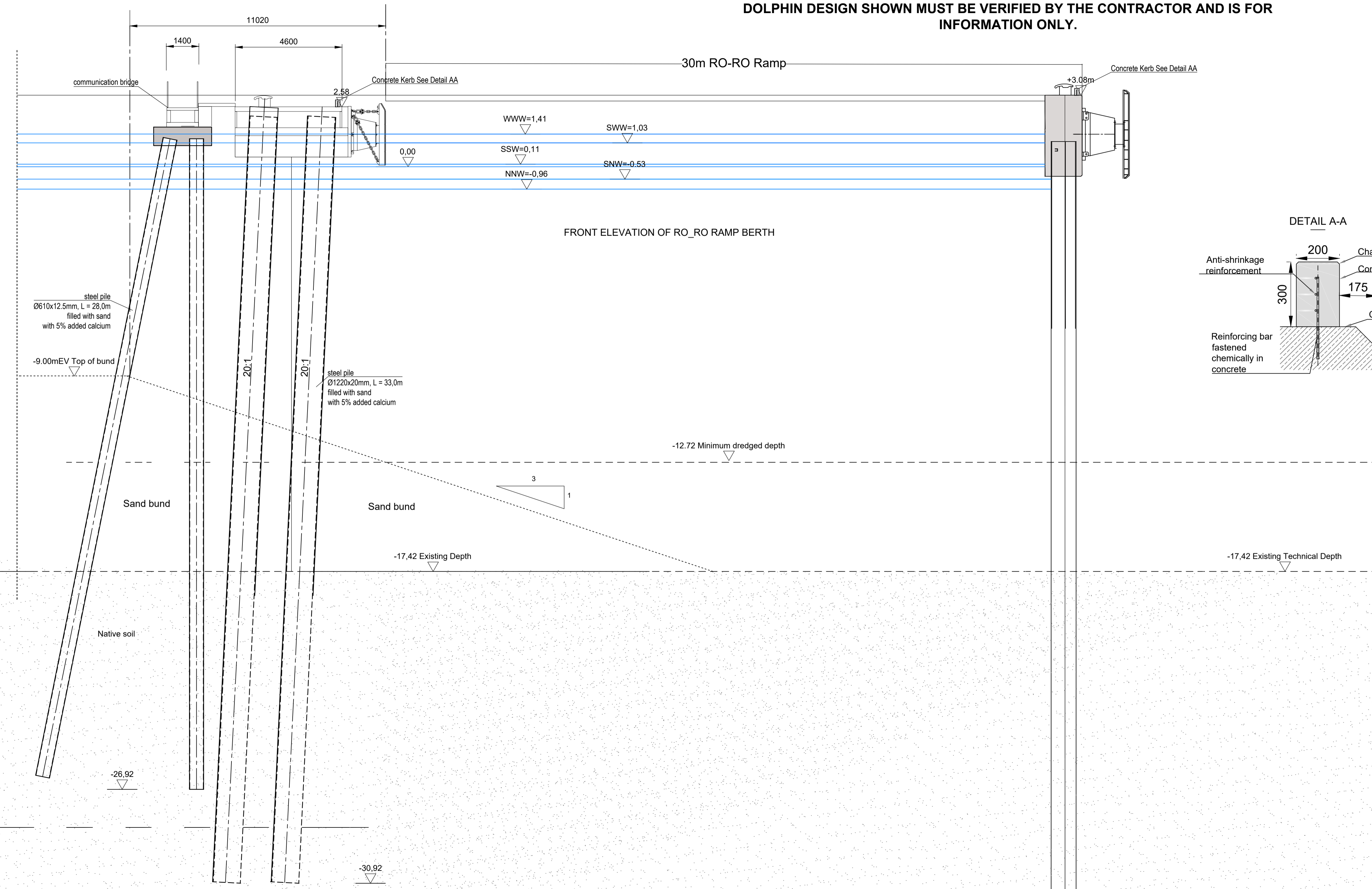

NOT FOR CONSTRUCTION

TENDER

Revision	Date	Description	Drawn	Checked	Approved
P04	05/12/23	Tender Issue	ADT	AT	CSJ
P03	21/11/23	Tender Issue	ADT	AT	CSJ
P02	31/10/23	Tender Issue	ADT	AT	CSJ
P01	29/09/23	Draft tender issue	ADT	AT	CSJ
P00	11/08/23	Draft for comment	ADT	AT	CSJ

Client: ISTRANA / Baltic Hub Container Terminal Sp. z o.o.

Baltic Hub ISTRANA/ Baltic Hub Container Terminal Sp. z o.o.
ul. Kontenerowa 7, 80-601 Gdańsk

Project: **BALTIC HUB T5 OFFSHORE WIND TERMINAL PROJECT**

Drawing Title: **RO-RO BERTH ELEVATION**

Designing company: HaskoningDHV Polska Sp. z o.o. ul. Dzielna 60 01-029 Warszawa	Date: 11/08/23	Scale: 1:100	Approved: AT
Drawing number: PC1063-RHD-T5-OW-DR-CM-3005	SUITABILITY: S4	REVISION: P04	